

Coriolis Flow Solutions for a Global Marketplace



www.tricorflow.com

DECADES of EXPERIENCE = EXCEPTIONAL RESULTS

When you combine decades of experience with truly unique talents, great things can happen. TRICOR Coriolis technology may be a new name on the scene but our engineers have been intimately involved with the development and evolution of Coriolis flow instrumentation since the beginning. In fact, many of the critical patents for Coriolis technology bear our engineers' names.

TRICOR Coriolis Technology products were designed and engineered in Colorado, Wisconsin and Germany. Our state-of-the-art manufacturing facility in Germany is equipped with superior calibration and test equipment that guarantees the performance of your instrument from the time it arrives at your site.

Our promise to you is that we will deliver high quality Coriolis technology, supported by the very experts who crafted the original technology.

Expertise, Accuracy, Value and Quality are the attributes that enable TRICOR Coriolis Technology to exceed our clients' expectations and leave a positive impact on the industries they serve.



QUALITY MANUFACTURING

TRICOR Coriolis Technology flow meters and transmitters are manufactured and calibrated by Coriolis experts using state-of-the-art equipment in our new 43,000 square foot manufacturing facility in Germany. We have chosen world-class suppliers of high quality components, all with demonstrated quality control systems and procedures. We have assembled manufacturing teams of German precision welders and assemblers with intense attention to detail, to ensure we consistently deliver quality Coriolis mass flow meters. Our focus on quality is put into action with our TRICOR Quality Program which keeps production teams organized and working in clean environments, maintaining our high product quality.



FEATURES:

- High accuracy
- No moving parts
- Ability to measure mass flow rate, volumetric flow rate, density and temperature
- 316L stainless steel flow tubes allow measurement of a wide range of materials



FLOW RATE:

Model Number	Traditional Meter Size	Max. Flow Rate			Internal Tube Diameter		Pressure Rating	
		(Kg/Hr)	(Lbs/Min)	(Gal/Min)	(mm)	(in)	(psig)	(bar)
TCM 325	1/8"	300	11	1.31	4 mm*	0.157"	2900	200
TCM 650	1/8"	600	22	2.64	4 mm	0.157"	2900	200
TCM 1550	1/4"	1500	55	6.59	8 mm*	0.315"	2900	200
TCM 3100	1/4"	3000	110	13.19	8 mm	0.315"	2900	200
TCM 5500	1/2"	5500	202	24.2	7 mm	0.276"	5000	345
TCM 28K	1"	28.8K	1056	126.6	16 mm	0.630"	1450	100
TCM 65K	2"	65K	2400	288	28 mm	1.1"	1450	100

* Double loop design.

MATERIALS OF CONSTRUCTION:

Wetted Parts: 316L SS seamless tubing

Case: 304 SS

Flow Splitter: CF3M (316 SS)

Brazing Alloy: BNi5

HAZARDOUS AREA CLASSIFICATIONS:

Designed to meet ratings and/or certifications specified.

ATEX Ex ib IIC T1-T6



ACCURACY:

Mass Flow Repeatability:

Repeatability = $\pm 1/2(\text{zero stability} / \text{flow rate}) * 100\%$ of rate

Zero Stability (0.01% full scale):

Model No.	(lb/min)	(kg/hr)
TCM 325	0.0012	0.033
TCM 650	0.0024	0.065
TCM 1550	0.0057	0.155
TCM 3100	0.0114	0.310
TCM 5500	0.0202	0.550
TCM 28K	0.1029	2.800
TCM 65K	0.2388	6.500

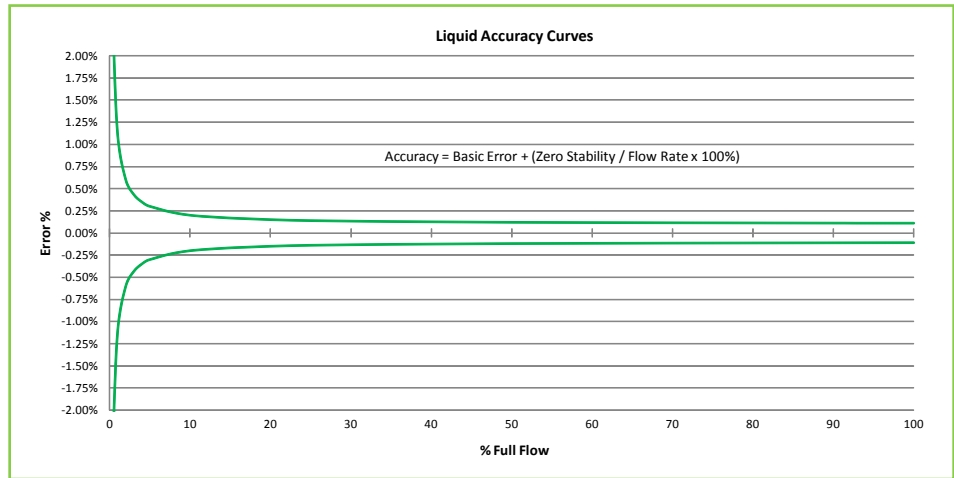

Basic Error:

Mass $\pm 0.10\%$

Volumetric $\pm 0.15\%$

Stated accuracy combines the effects of repeatability, linearity, and hysteresis.

Accuracy rate $\pm (\text{zero stability}/\text{flow rate}) * 100\%$ of flow rate.

DENSITY:

Density Accuracy: Liquids: $\pm 1.0 \text{ kg/m}^3$, $\pm 0.001 \text{ g/cm}^3$, $\pm 0.062 \text{ lb/ft}^3$

Density Repeatability: $\pm 0.5 \text{ kg/m}^3$, $\pm 0.0005 \text{ g/cm}^3$, $\pm 0.031 \text{ lb/ft}^3$

Density Range: Up to 5000 kg/m^3 (5 g/cm^3 , 5.0 S.G), $\pm 312 \text{ lb/ft}^3$

TEMPERATURE:

Media Temperature Range: -150 to 302° F (-100 to 150° C)

Temperature Accuracy:

- $\pm 1.0^\circ \text{ C}$, $\pm 0.5\%$ of reading
- Repeatability $\pm 0.1\%$
- May require a special platinum RTD for cold temps (-40 deg and below).

Ambient Temperature Limits: -40° to 140° F
(-40° C to 284° C)

PRESSURE:

Max Pressure: see chart page 3

Process Pressure Effect:

Mass Flow Accuracy: $\pm 0.001\%$ of rate per PSI

Density Accuracy: $\pm 0.00003 \text{ g/cm}^3$ per PSI



METER DIMENSIONS:

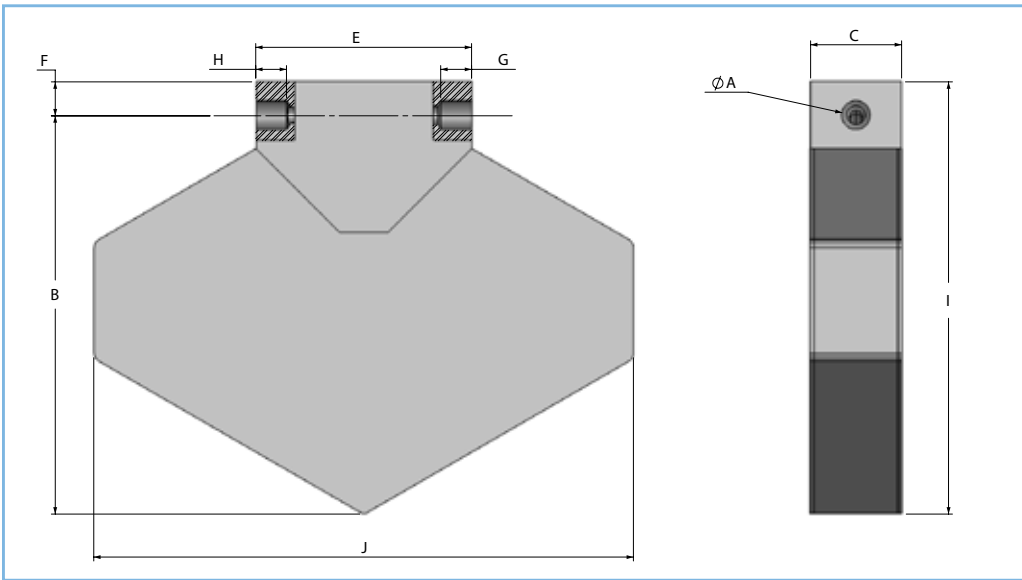

Dimension	TCM 325 & 650	TCM 1550 & 3100
A	1/2" BSPP	1/2" BSPP
B	160 mm (6-1/4")	259 mm (10-3/16")
C	60 mm (2-3/8")	59 mm (2-5/16")
E	109 mm (4-5/16")	140 mm (5-1/2")
F	22 mm (7/8")	22 mm (7/8")
G	19 mm (3/4")	22 mm (7/8")
H	19 mm (3/4")	22 mm (7/8")
I	182 mm (7-3/16")	281 mm (11-1/16")
J	214 mm (8-7/16")	349 mm (13-3/4")

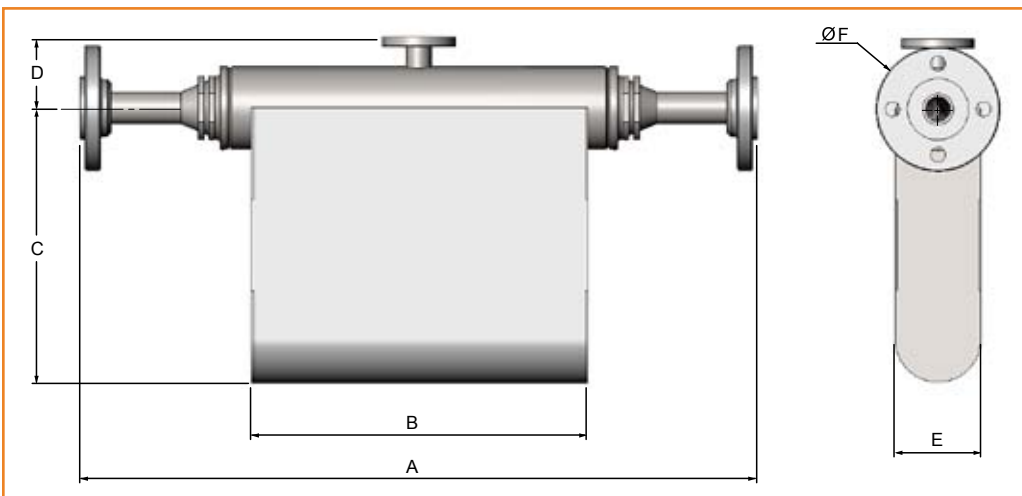
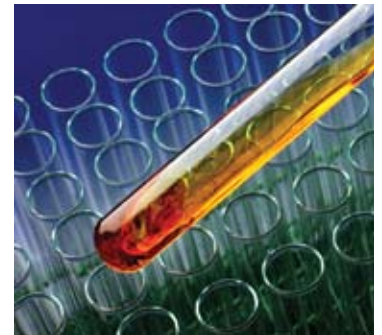

Dimension	TCM 5500	TCM 28K	TCM 65K
A	639.9 mm (25-1/4")	625 mm (24.6")	832 mm (32-3/4")
B	294 mm (11-1/2")	311 mm (12-1/4")	550 mm (21-11/16")
C	194.1mm (7.6")	254 mm (10")	415 mm (16-3/8")
D	37.5 mm (1-1/2")	63.5 mm (2-1/2")	99 mm (3-15/16")
E	57mm (2-1/4")	80.1 mm (3-3/16")	133 mm (5-1/4")
F	see note	see note	see note



Note: All ANSI, DN and Tri-Clamp flange sizes available. Consult factory for flange dimension F.

ELECTRONICS:

The TCE-8000 electronic transmitters come in 3 different mounting options:

- Integral Field Mount
- Remote Field Mount
- Panel Mount

Display: Graphic, 132 x 32 dot

Supply voltage: 24 VDC ($\pm 20\%$); 90-240 VAC

Programming: via front keyboard

Interface: RS 485, options HART®, Foundation™ Fieldbus, Modbus®

Power consumption: max. 4 W

Analog Outputs:	
Two current outputs	4-20 mA passive, two-wire insulated
Resolution	14 bit
Linearity	+0.05% of full scale
Temperature drift	0.05% per 10°C
Load	< 800 Ohm
Output value	programmable: flow, total, density, temperature

Pulse Output:	
Frequency range	0.5 - 10,000 Hz
Output signal	Active push-pull output of flow rate or cycle output

Status In- and Output:	
Status output	fault out info (push-pull)
Control input	programmable

Field-mounted Housing:	
Connections	internal clamp terminals 1/2" female NPT cable gland
Protection class	IP 68
Weight	approx 2 kg
Temperature	operating: 0 up to 50°C storage & transport: -20 up to 70°C

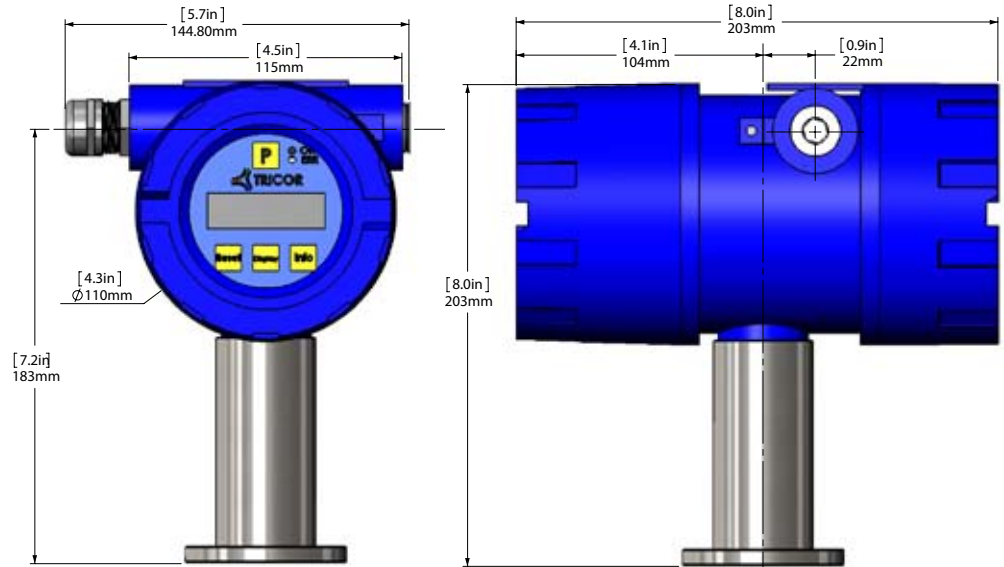

Panel-mounted Housing:	
Connections	rear screw type terminals
Material	Noryl
Protection class	front: IP 40, rear: IP 30
Weight	approx 500g
Temperature	operating: 0 to 50°C storage & transport: -20 up to 70°C

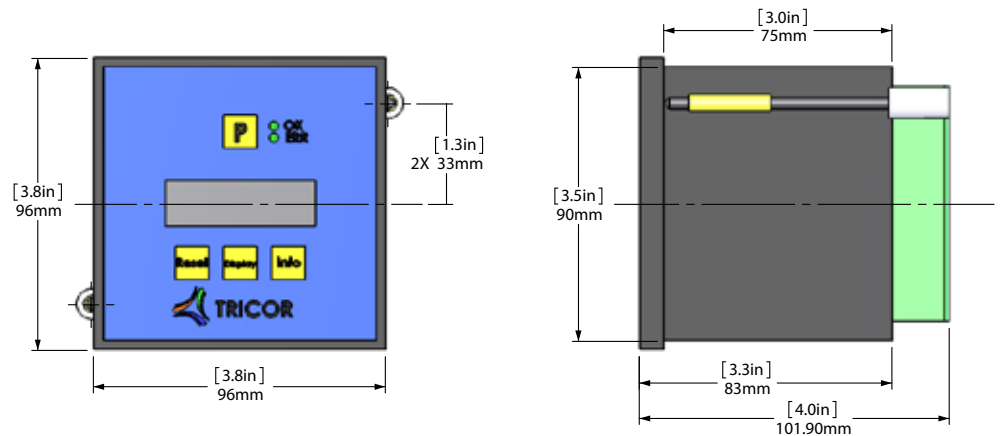

Junction Box (factory-installed for Remote Field Mount & Panel Mount Configurations):	
Connections	internal screw type terminals; 1/2" female NPT cable gland
Temperature	operating: 0 to 50°C storage & transport: -20 up to 70°C

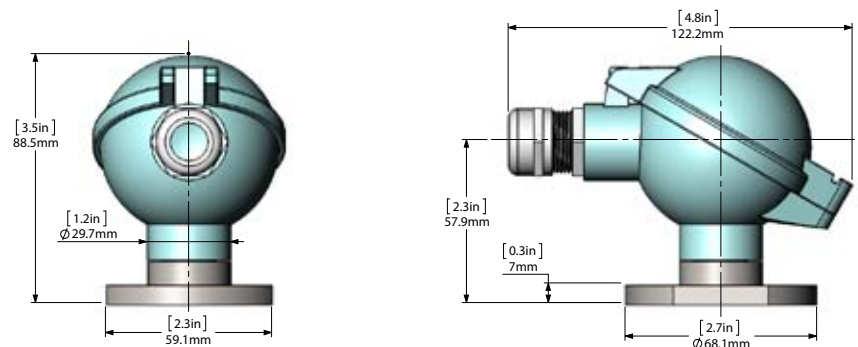

ORDERING INFORMATION:

TCM Series Part Numbering

TCM **028k** - [] - [] - [] - []

Max. flow in Kg/h

Process Connections

code	ANSI Flange	code	DIN Flange
AA	0.5" CL 150	DA	DN15 PN40 EN 1092-1 Form B1
AB	0.5" CL 300	DB	DN15 PN100 EN 1092-1 Form B1
AC	0.5" CL 600	DC	DN25 PN40 EN 1092-1 Form B1
AD	0.5" CL 900	DD	DN25 PN100 EN1092-1 Form B1
AE	1.0" CL 150	DE	DN40 PN 40 EN 1092-1 Form B1
AF	1.0" CL 300	DF	DN40 PN 100 EN 1092-1 Form B1
AG	1.0" CL 600	DG	DN50 PN 40, EN 1092-1 Form B1
AH	1.0" CL 900	DH	DN50 PN 100, EN 1092-1 Form B1
AJ	1.5" CL 150	DJ	DN80 PN 40, EN 1092-1 Form B1
AK	1.5" CL 300	DK	DN80 PN 100, EN 1092-1 Form B1
AL	1.5" CL 600	DL	DN100 PN 40, EN 1092-1 Form B1
AM	1.5" CL 900	DM	DN100 PN 100, EN 1092-1 Form B1
AN	2.0" CL 150	DN	DN125 PN 40, EN 1092-1 Form B1
AO	2.0" CL 300	DO	DN125 PN 100, EN 1092-1 Form B1
AP	2.0" CL 600	DP	DN25 PN 250, EN 1092-1 Form B1
AR	2.0" CL 900	code	DIN 11851 Flange
AS	3.0" CL 150	RA	DN 15
AT	3.0" CL 300	RB	DN 25
AU	3.0" CL 600	RC	DN 40
AV	3.0" CL 900	RD	DN 50
AW	4.0" CL 150	RE	DN 19
AX	4.0" CL 300	RF	DN 80
AY	4.0" CL 600	RG	DN 100
AZ	4.0" CL 900	code	JIS Flange
code	Triclamp Flange	JA	JIS 15mm 10K/20K
TA	0.5"	JB	JIS 15mm 40K
TB	0.75"	JC	JIS 15mm 40K
TC	1.0"	JD	JIS 25mm 10K/20K
TD	1.5"	JE	JIS 25mm 40K
TE	2.0"	JF	JIS 25mm 40K
TF	2.5"	JG	JIS 40mm 10K
TG	3"	JH	JIS 40mm 20K
TH	4"	JJ	JIS 50mm 10K
code	Female Thread	JK	JIS 50mm 20K
FA	0.5" BSPP	JL	JIS 50mm 40K
		JM	JIS 80mm 10K
		JN	JIS 80mm 20K
		JP	JIS 100mm 10K
		JR	JIS 100mm 20K

code	Ex Protection
Ex	Ex-protection
empty	no Ex-protection

code	Electronics / Terminal (4 digits)
X000	Electronics: X = no electronics (replacement only) A = junction box C = on site electronics
0X00	Interface: A = HART B = Foundation™ Fieldbus C = both (HART® & Foundation™ Fieldbus) D = RS-485 (standard) G = Modbus®
00X0	Supply voltage: D = 24 VDC (standard) M = 90 - 264 VAC (upon request)
000X	X (reserved for future options)

code	Mechanical Options (4 digits)
X000	Temperature range: S = -20° to 100°C L = -100° to 100°C H = -20° to 200°C
0X00	Pressure range: A = 90 psi E = 580 psi G = 1450 psi H = 5000 psi
00X0	Accuracy: S = standard
000X	Length: S = standard M = maximum

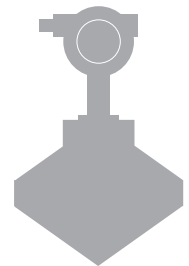

integral field mount

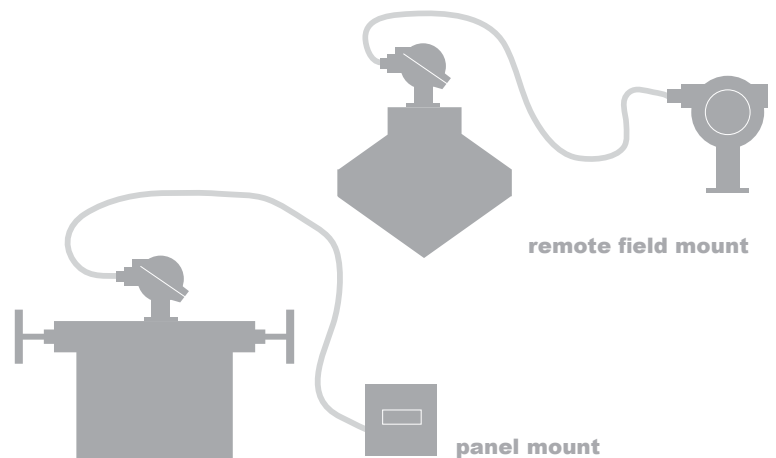

remote field mount

panel mount

To find a dealer in your area, visit:

www.tricorflow.com/locations

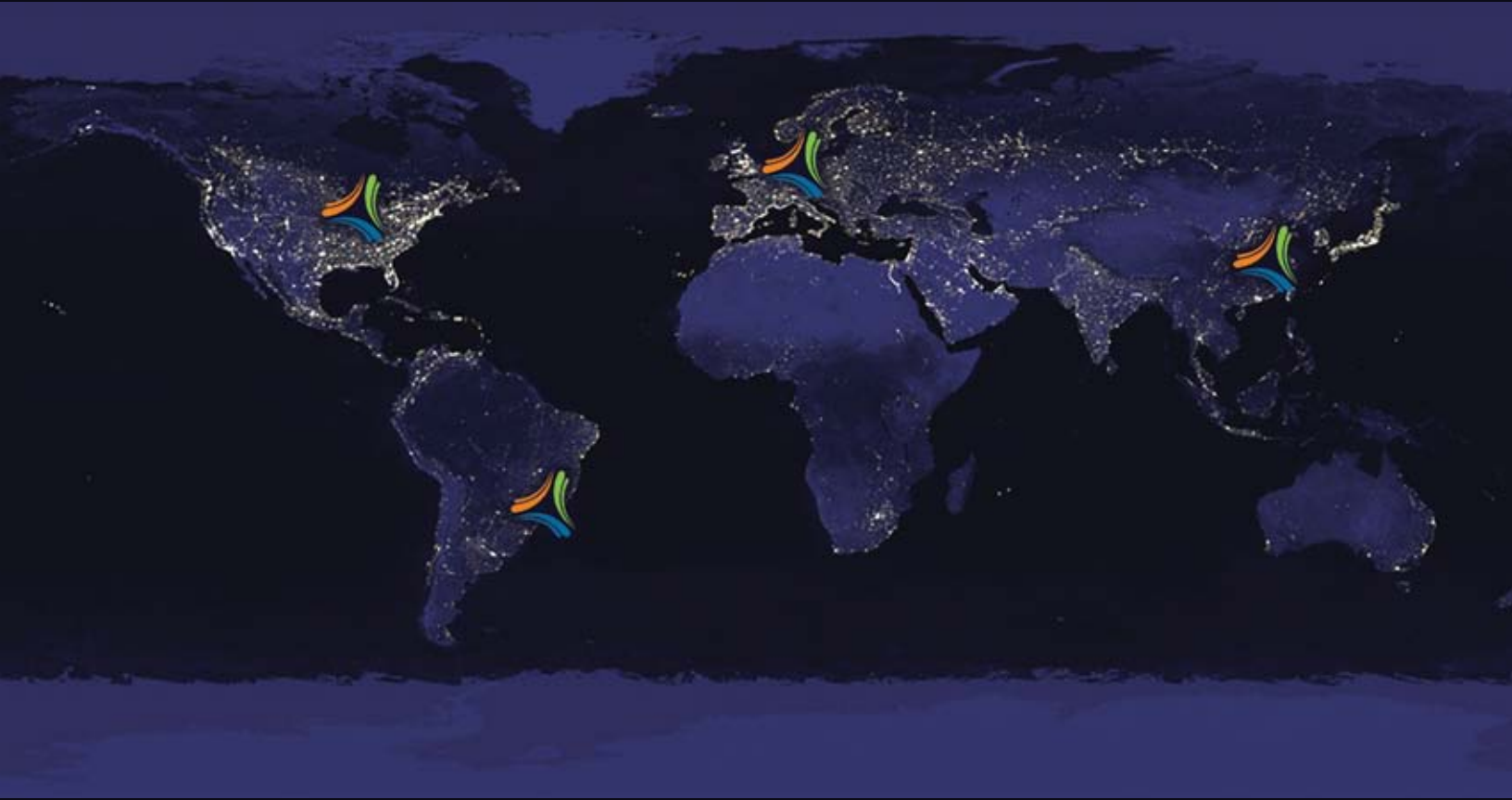

Americas:
AW-Lake Company
8809 Industrial Drive
Frankville, WI 53126 USA
Tel.: 800-850-6110

Europe:
KEM Kuppers
Liebigstraße 2
85757 Karlsfeld, Germany
Tel.: +49 (0)8131 59391-0

Asia:
TASI Flow
Rm.2429, JinYuan Office Building, No. 36
CN- BeiYuan Road, Beijing 100012
P.R.CHINA
Tel.: +86 10 520 037 38