

# RAMPE GAS - GAS TRAINS

# ITALPUMP

## Gas Train DN 65



### LEGENDA:

1. FILTRO
2. VALVOLA BLOCCO DI MASSIMA PRESSIONE (OPZO)
3. REGOLATORE DI PRESSIONE
4. VALVOLA DI SFIORO
5. PRESSOSTATO
6. ELETTROVALVOLA AUTOMATICA AD APERTURA RAPIDA
7. ELETTROVALVOLA AUTOMATICA AD APERTURA LENTA



### LEGEND:

1. GAS FILTER
2. OVER PRESSURE SLAM SHUT-OFF VALVE (OPZO)
3. GAS PRESSURE REGULATOR
4. RELIEF VALVE
5. PRESSURE SWITCH
6. AUTOMATIC FAST OPENING SOLENOID VALVE
7. AUTOMATIC SLOW OPENING SOLENOID VALVE



# RAMPE GAS - GAS TRAINS

# ITALPUMP

## Gas Train DN 80

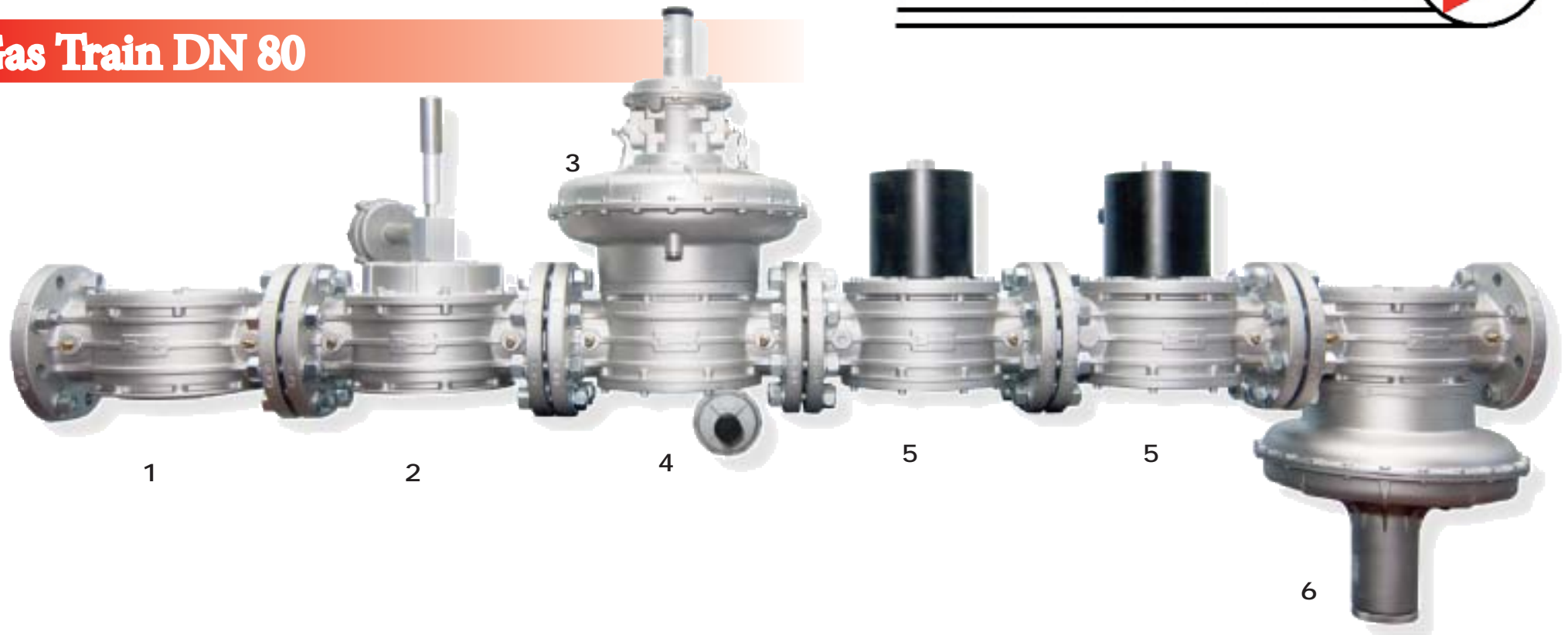

### LEGENDA:

1. FILTRO
2. VALVOLA BLOCCO DI MASSIMA PRESSIONE (OPSO)
3. REGOLATORE DI PRESSIONE
4. VALVOLA DI SFIORO
5. ELETTROVALVOLA AUTOMATICA AD APERTURA RAPIDA
6. REGOLATORE DI ZERO



### LEGEND:

1. GAS FILTER
2. OVER PRESSURE SLAM SHUT-OFF VALVE (OPSO)
3. GAS PRESSURE REGULATOR
4. RELIEF VALVE
5. AUTOMATIC FAST OPENING SOLENOID VALVE
6. ZERO PRESSURE REGULATOR



# RAMPE GAS - GAS TRAINS

# ITALPUMP

## Gas Train DN 100

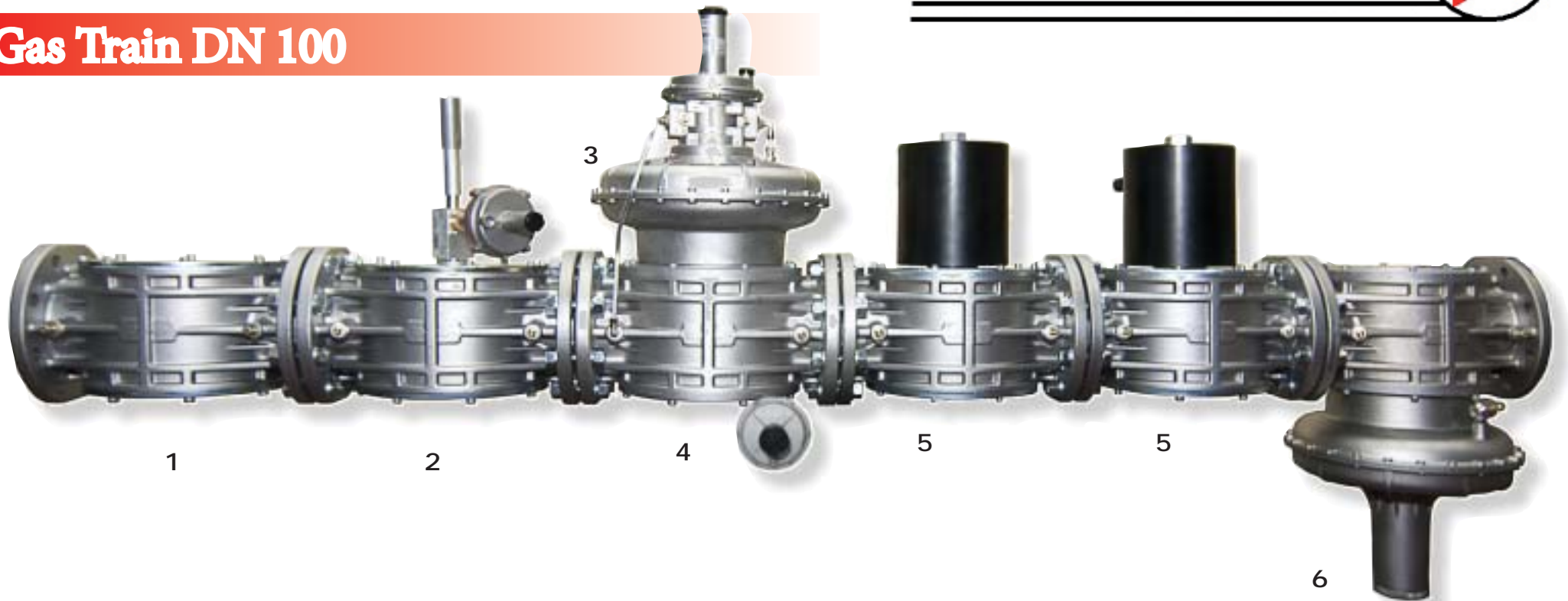

### LEGENDA:



1. FILTRO
2. VALVOLA BLOCCO DI MASSIMA PRESSIONE (OPSO)
3. REGOLATORE DI PRESSIONE
4. VALVOLA DI SFIORO
5. ELETTROVALVOLA AUTOMATICA AD APERTURA RAPIDA
6. REGOLATORE DI ZERO

### LEGEND:



1. GAS FILTER
2. OVER PRESSURE SLAM SHUT-OFF VALVE (OPSO)
3. GAS PRESSURE REGULATOR
4. RELIEF VALVE
5. AUTOMATIC FAST OPENING SOLENOID VALVE
6. ZERO PRESSURE REGULATOR

# RAMPE GAS - GAS TRAINS

# ITALPUMP

## Gas Train DN 65

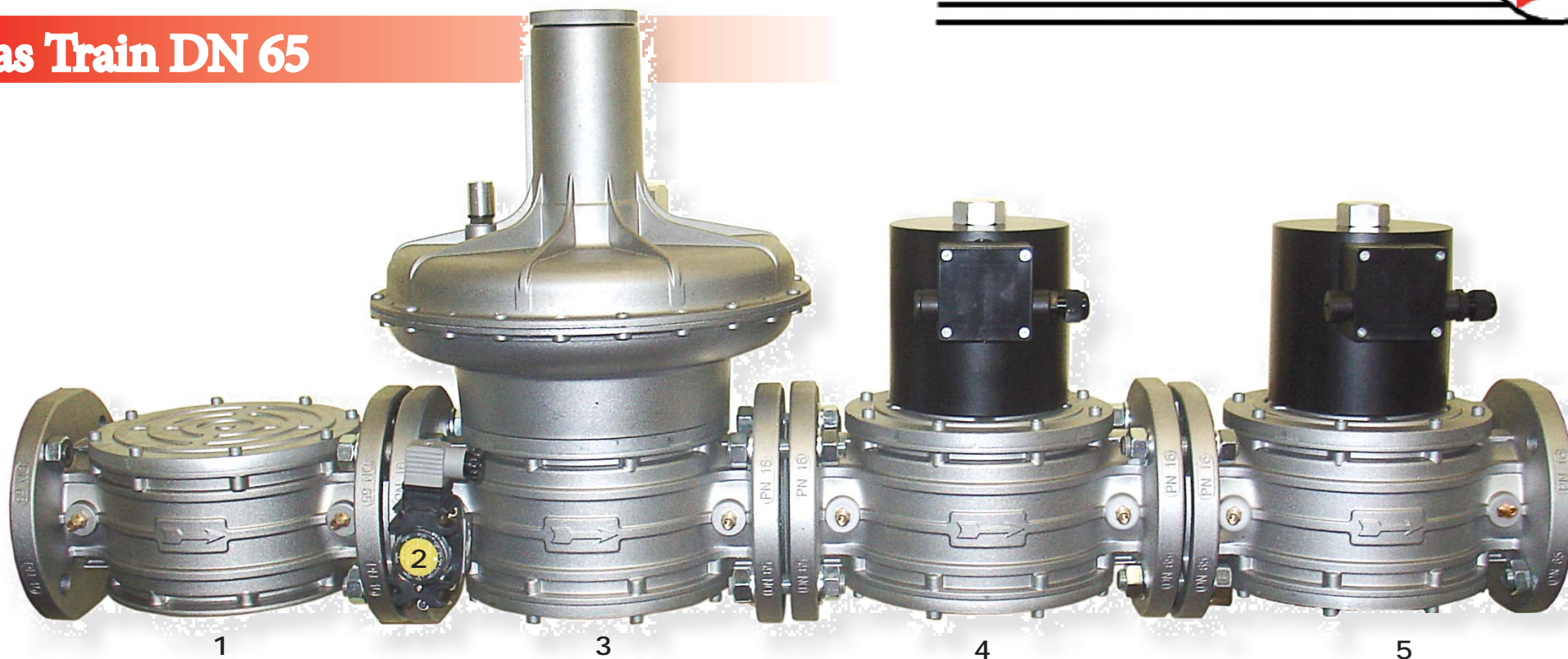

### LEGENDA:

1. FILTRO
2. PRESSOSTATO
3. REGOLATORE DI PRESSIONE
4. ELETTROVALVOLA AUTOMATICA AD APERTURA RAPIDA
5. ELETTROVALVOLA AUTOMATICA AD APERTURA RAPIDA



### LEGEND:

1. GAS FILTER
2. PRESSURE SWITCH
3. GAS PRESSURE REGULATOR
4. AUTOMATIC FAST OPENING SOLENOID VALVE
5. AUTOMATIC FAST OPENING SOLENOID VALVE



# RAMPE GAS - GAS TRAINS

# ITALPUMP

## Gas Train DN 50

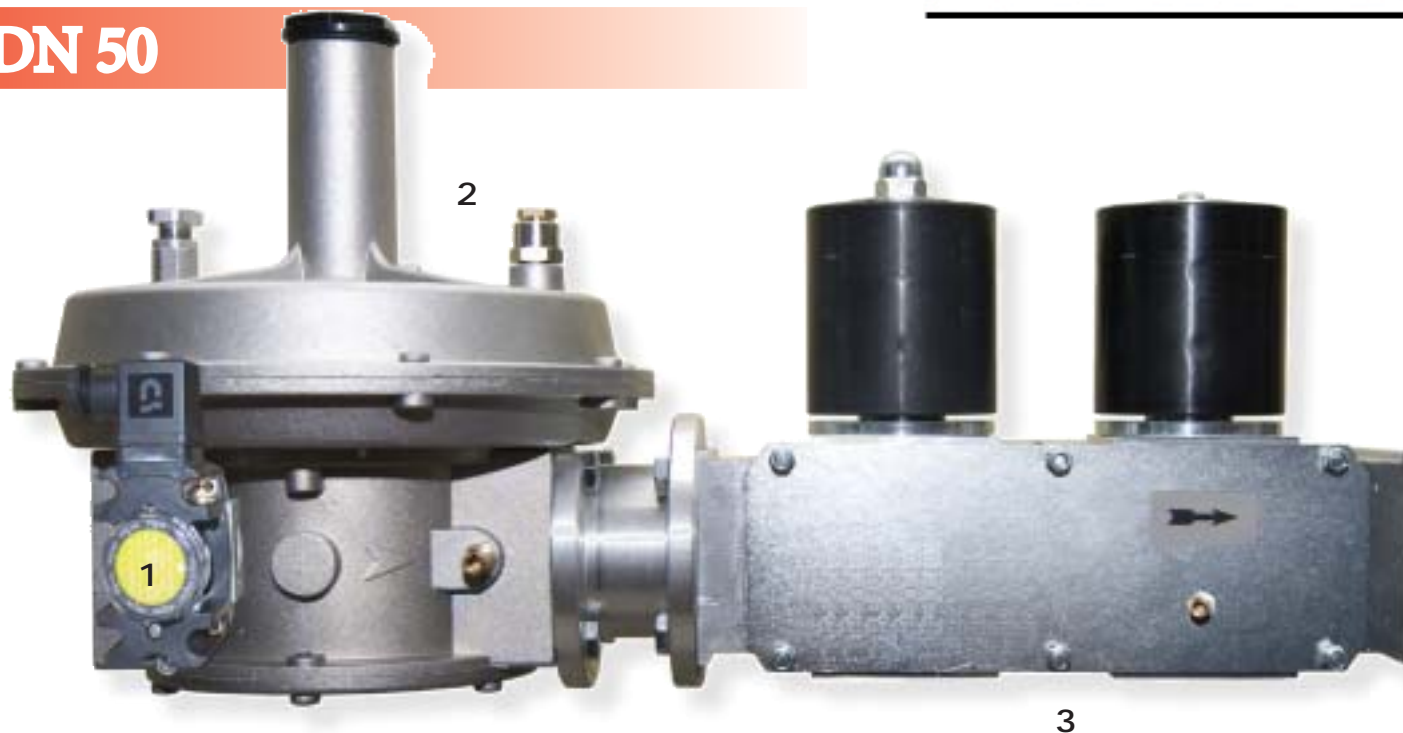

### LEGENDA:

1. PRESSOSTATO
2. REGOLATORE DI PRESSIONE
3. ELETTROVALVOLA DOPPIA



### LEGEND:

1. PRESSURE SWITCH
2. GAS PRESSURE REGULATOR
3. DOUBLE SOLENOID VALVE



# RAMPE GAS - GAS TRAINS

# ITALPUMP

## Gas Train DN 50

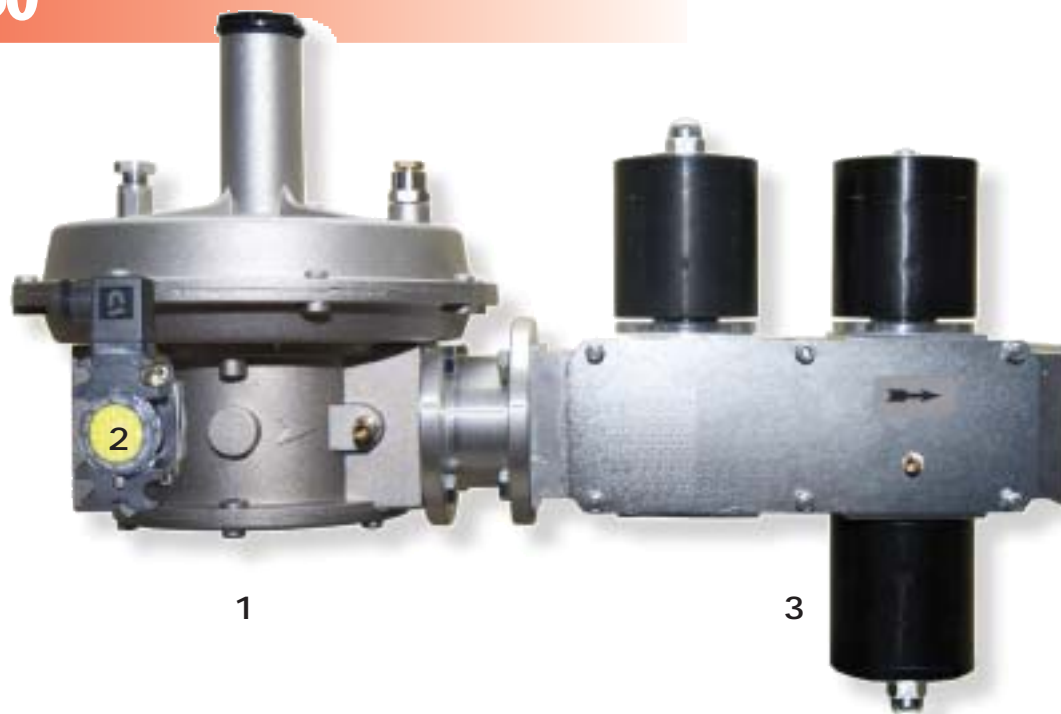

1

3

### LEGENDA:

1. PRESSOSTATO
2. REGOLATORE DI PRESSIONE
3. ELETTROVALVOLA DOPPIA BISTADIO



### LEGEND:

1. PRESSURE SWITCH
2. GAS PRESSURE FILTER REGULATOR
3. DUAL STAGE DOUBLE SOLENOID VALVE



# RAMPE GAS - GAS TRAINS

# ITALPUMP

## Gas Train DN 65

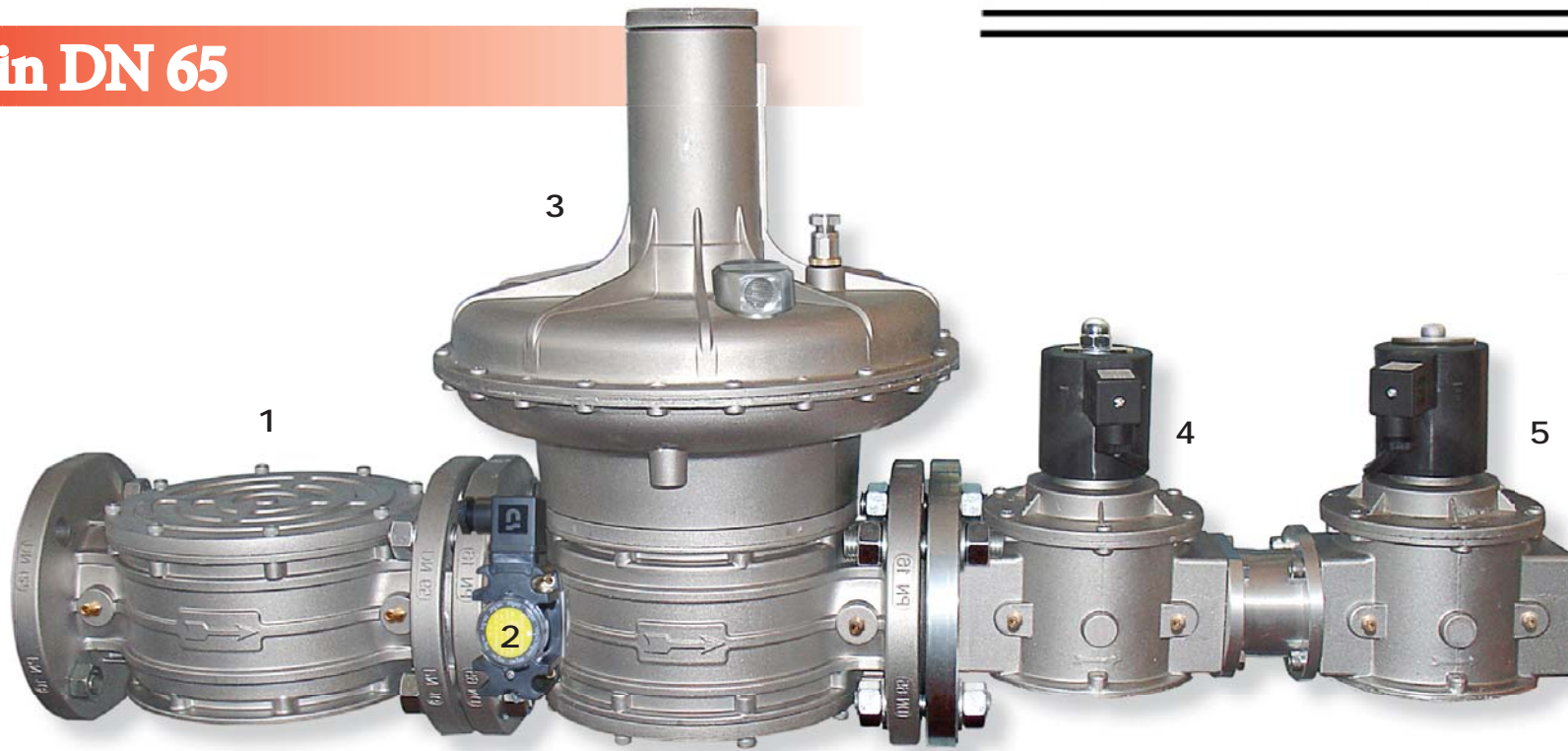

### LEGENDA:

1. FILTRO
2. PRESSOSTATO
3. REGOLATORE DI PRESSIONE
4. ELETTROVALVOLA RAPIDA CON REGOLATORE DI PORTATA
5. ELETTROVALVOLA RAPIDA



### LEGEND:

1. GAS FILTER
2. PRESSURE SWITCH
3. GAS PRESSURE REGULATOR
4. AUTOMATIC FAST OPENING SOLENOID VALVE WITH FLOW REGULATOR
5. AUTOMATIC FAST OPENING SOLENOID VALVE



# RAMPE GAS - GAS TRAINS

# ITALPUMP



## Gas Train DN 50

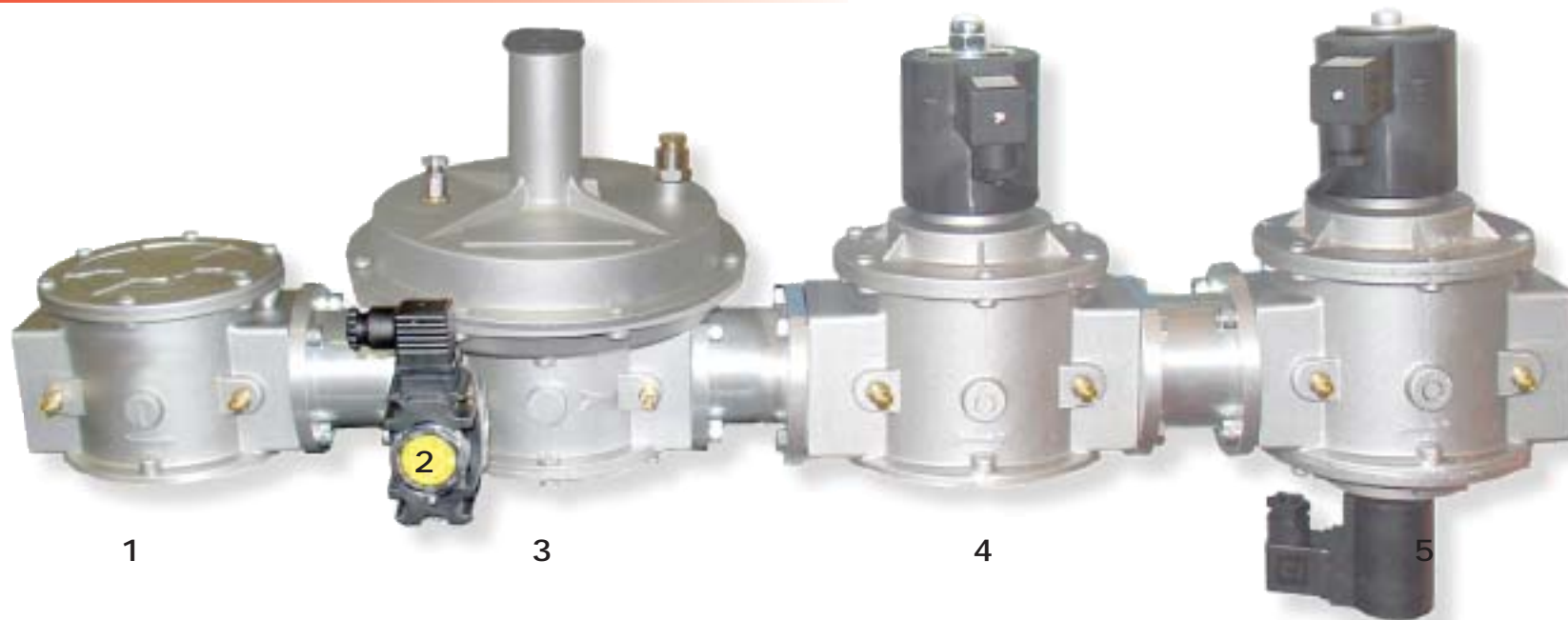

### LEGENDA:

1. FILTRO
2. PRESSOSTATO
3. REGOLATORE DI PRESSIONE
4. ELETTROVALVOLA AD APERTURA RAPIDA
5. ELETTROVALVOLA DOPPIA BISTADIO



### LEGEND:

1. GAS FILTER
2. PRESSURE SWITCH
3. GAS PRESSURE REGULATOR
4. AUTOMATIC FAST OPENING SOLENOID VALVE
5. DUAL STAGE SOLENOID VALVE





## Gas Train DN 65

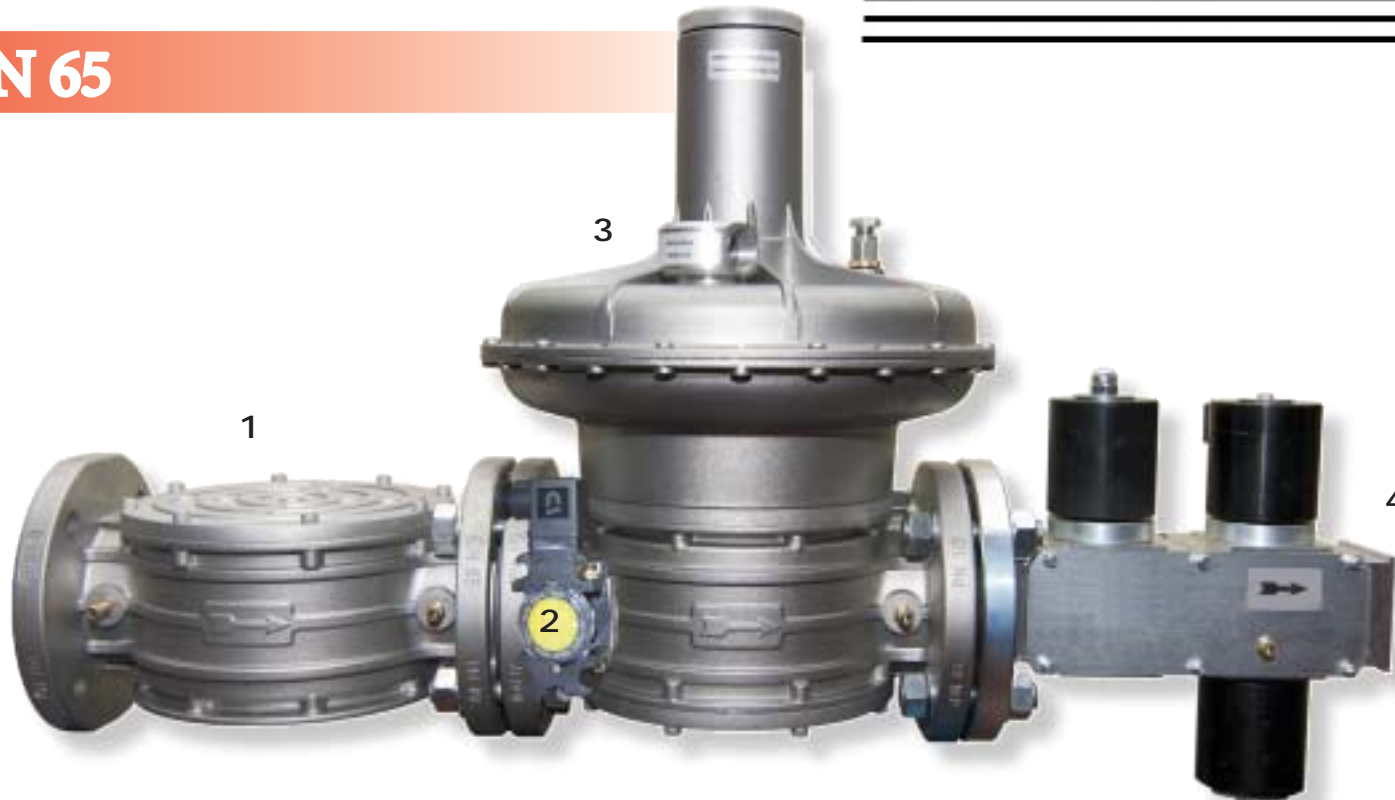

### LEGENDA:

1. FILTRO
2. PRESSOSTATO
3. REGOLATORE DI PRESSIONE
4. ELETTROVALVOLA DOPPIA BISTADIO



### LEGEND:

1. GAS FILTER
2. PRESSURE SWITCH
3. GAS PRESSURE REGULATOR
4. DUAL STAGE DOUBLE SOLENOID VALVE



## Gas Train DN 50

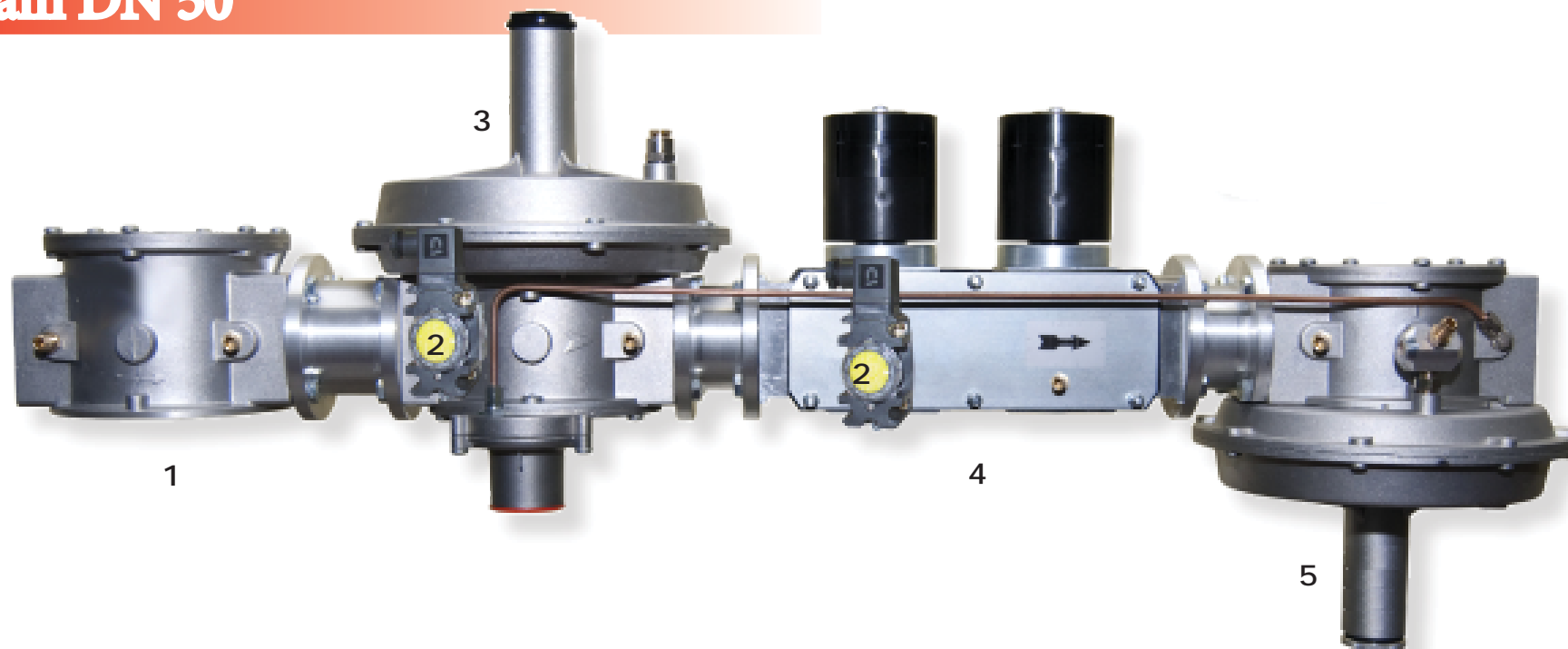

### LEGENDA:

1. FILTRO
2. PRESSOSTATO
3. REGOLATORE DI PRESSIONE
4. VALVOLA DOPPIA
5. REGOLATORE DI ZERO



### LEGEND:

1. GAS FILTER
2. PRESSURE SWITCH
3. GAS PRESSURE REGULATOR
4. DOUBLE SOLENOID VALVE
5. ZERO PRESSURE REGULATOR



# RAMPE GAS - GAS TRAINS

# ITALPUMP

## Gas Train DN 50

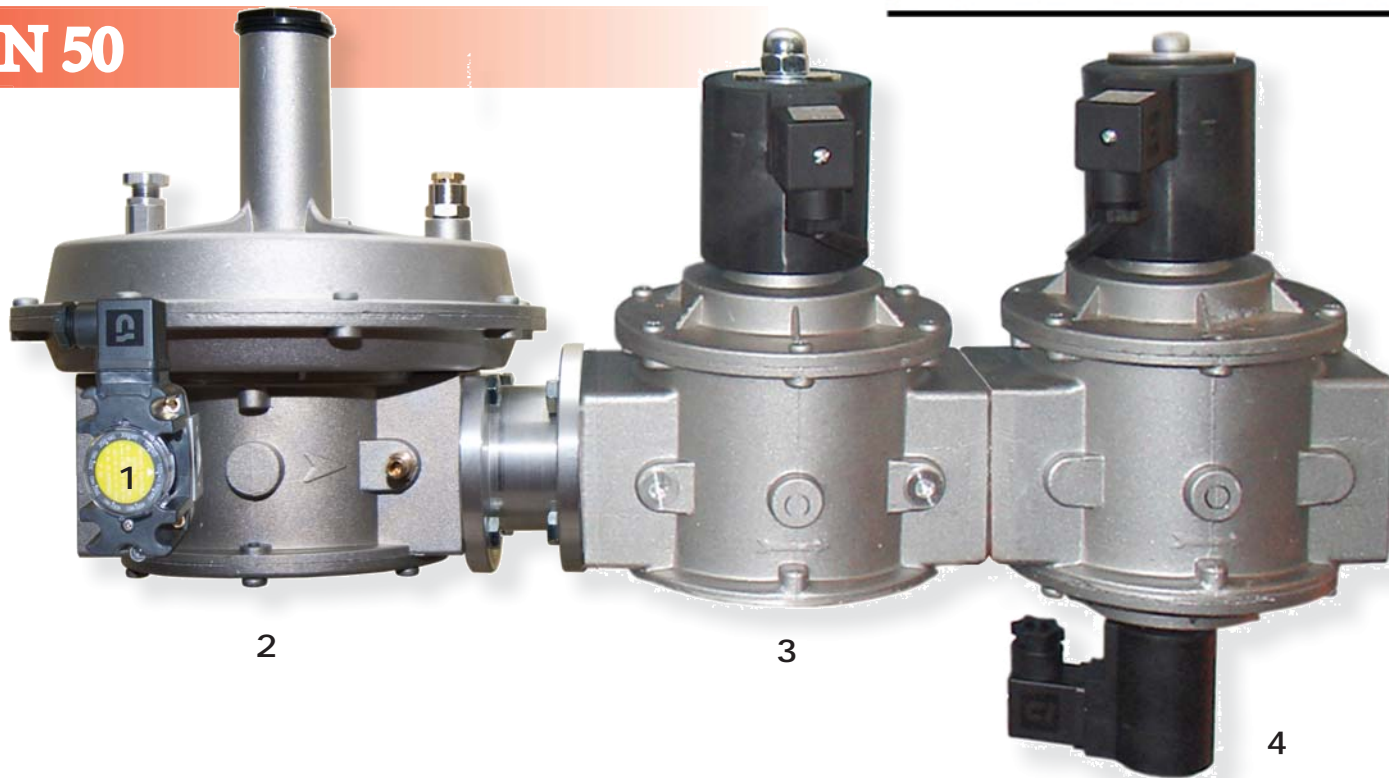

### LEGENDA:

1. PRESSOSTATO
2. REGOLATORE DI PRESSIONE
3. ELETTROVALVOLA AUTOMATICA AD APERTURA RAPIDA
4. ELETTROVALVOLA DOPPIA BISTADIO



### LEGEND:

1. PRESSURE SWITCH
2. GAS PRESSURE FILTER REGULATOR
3. AUTOMATIC FAST OPENING SOLENOID VALVE
4. DUAL STAGE SOLENOID VALVE



## Gas Train DN 40

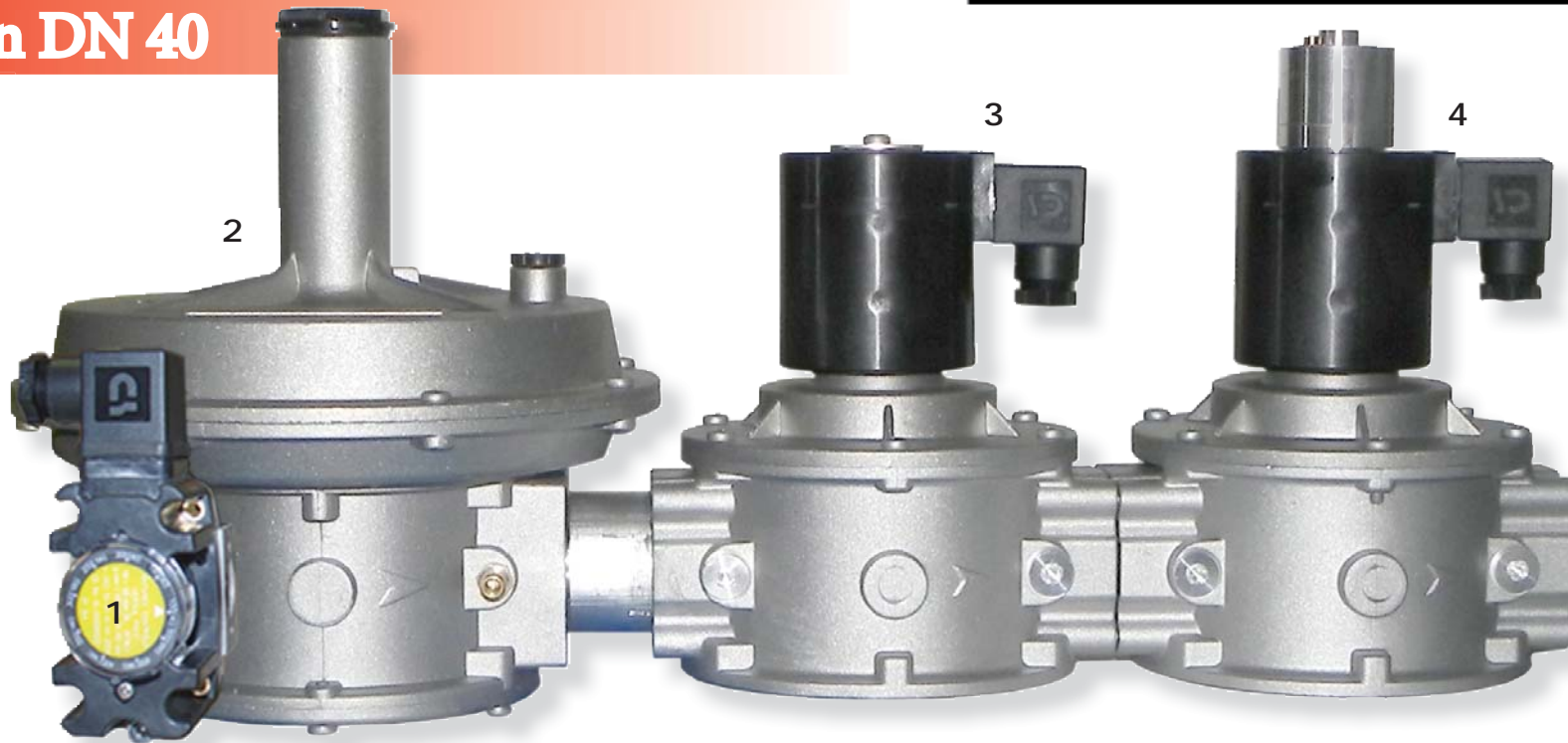

### LEGENDA:

1. PRESSOSTATO
2. REGOLATORE DI PRESSIONE DN 50
3. ELETTROVALVOLA AUTOMATICA AD APERTURA RAPIDA
4. ELETTROVALVOLA AUTOMATICA AD APERTURA LENTA



### LEGEND:

1. PRESSURE SWITCH
2. GAS PRESSURE REGULATOR DN 50
3. AUTOMATIC FAST OPENING SOLENOID VALVE
4. AUTOMATIC SLOW OPENING SOLENOID VALVE



## Gas Train DN 50

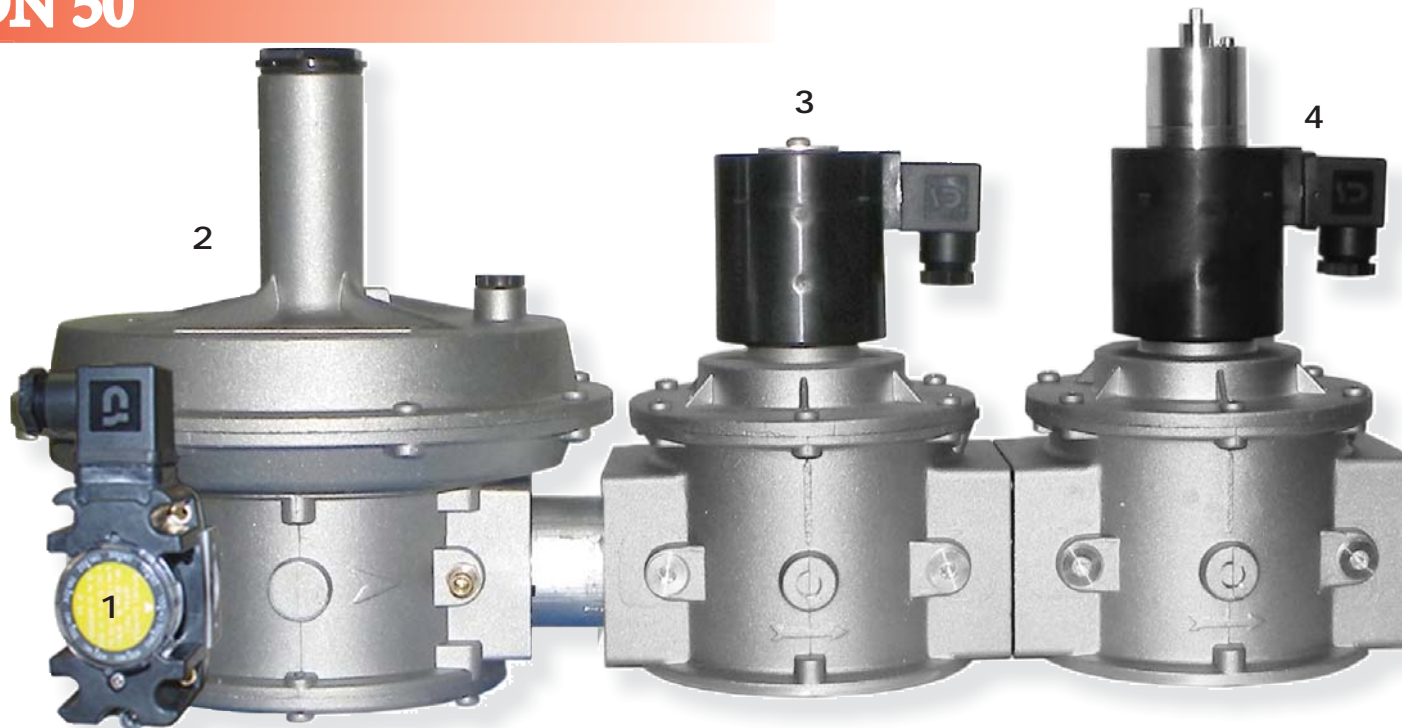

### LEGENDA:

1. PRESSOSTATO
2. REGOLATORE DI PRESSIONE
3. ELETTROVALVOLA AUTOMATICA AD APERTURA RAPIDA
4. ELETTROVALVOLA AUTOMATICA AD APERTURA LENTA



### LEGEND:

1. PRESSURE SWITCH
2. GAS PRESSURE FILTER REGULATOR
3. AUTOMATIC FAST OPENING SOLENOID VALVE
4. AUTOMATIC SLOW OPENING SOLENOID VALVE



## Gas Train DN 25

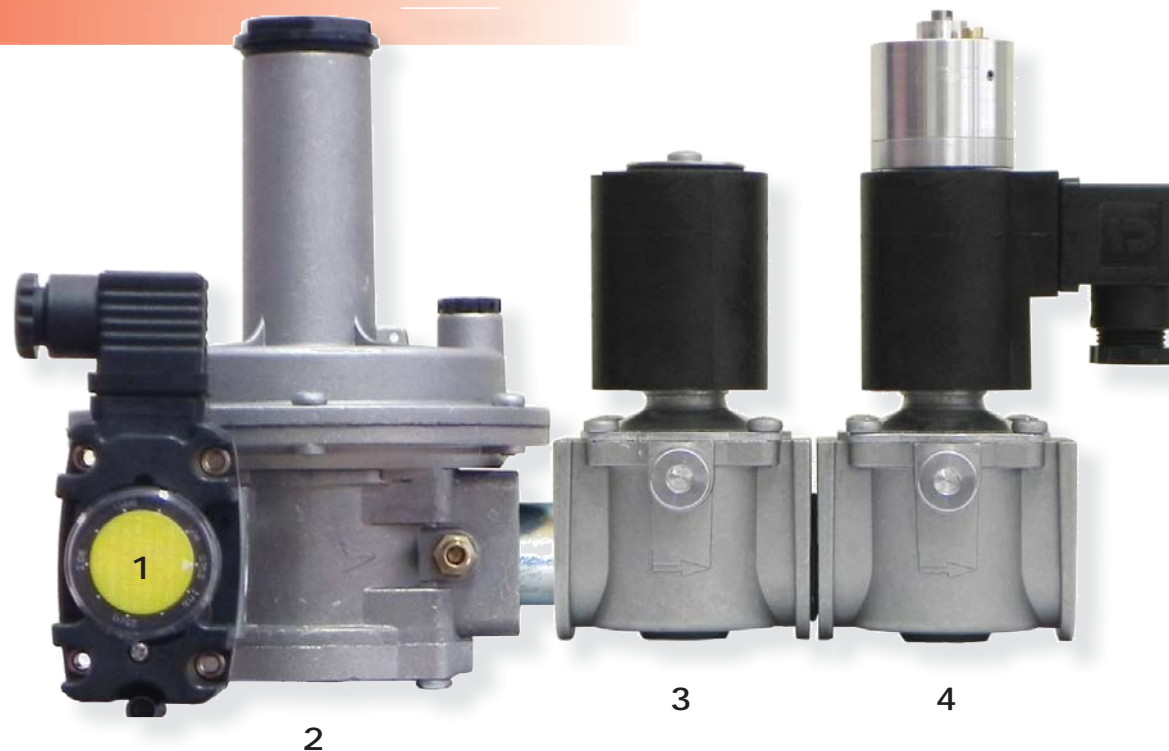

### LEGENDA:

1. PRESSOSTATO
2. REGOLATORE DI PRESSIONE
3. ELETTROVALVOLA AUTOMATICA AD APERTURA RAPIDA
4. ELETTROVALVOLA AUTOMATICA AD APERTURA LENTA



### LEGEND:

1. PRESSURE SWITCH
2. GAS PRESSURE FILTER REGULATOR
3. AUTOMATIC FAST OPENING SOLENOID VALVE
4. AUTOMATIC SLOW OPENING SOLENOID VALVE



## Gas Train DN 25

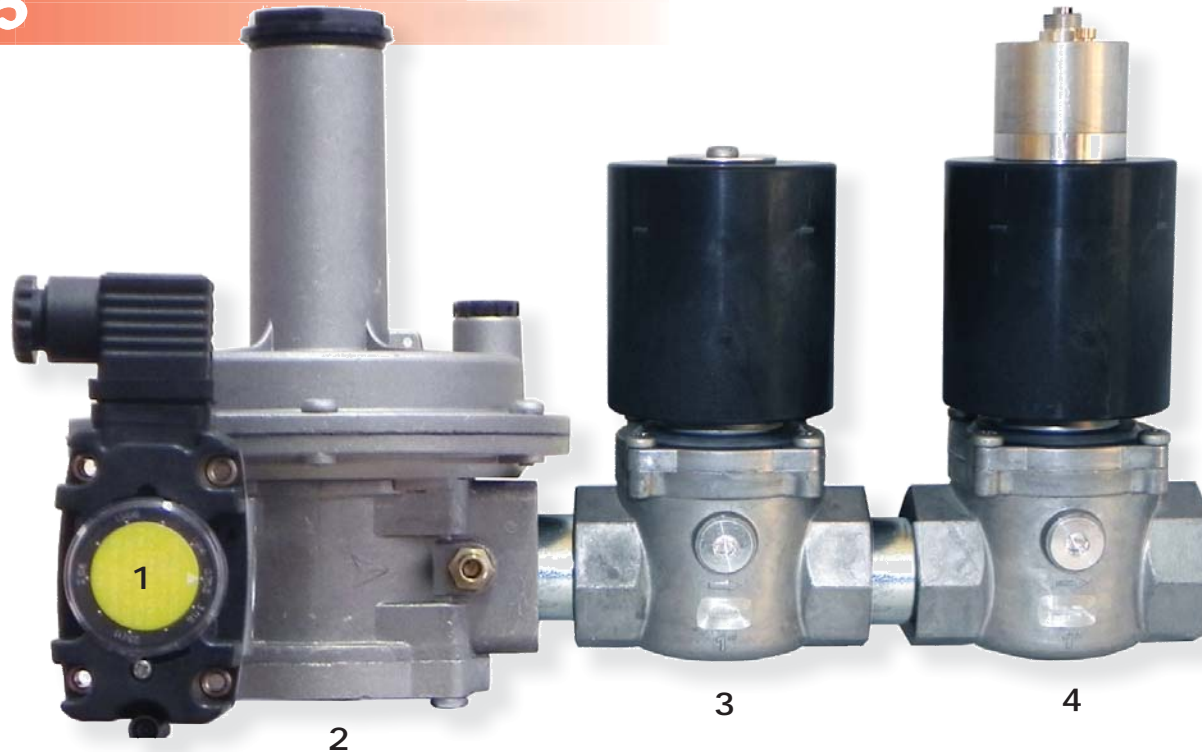

### LEGENDA:

1. PRESSOSTATO
2. REGOLATORE DI PRESSIONE
3. ELETTROVALVOLA AUTOMATICA AD APERTURA RAPIDA
4. ELETTROVALVOLA AUTOMATICA AD APERTURA LENTA



### LEGEND:

1. PRESSURE SWITCH
2. GAS PRESSURE FILTER REGULATOR
3. AUTOMATIC FAST OPENING SOLENOID VALVE
4. AUTOMATIC SLOW OPENING SOLENOID VALVE





## Gas Train DN 80

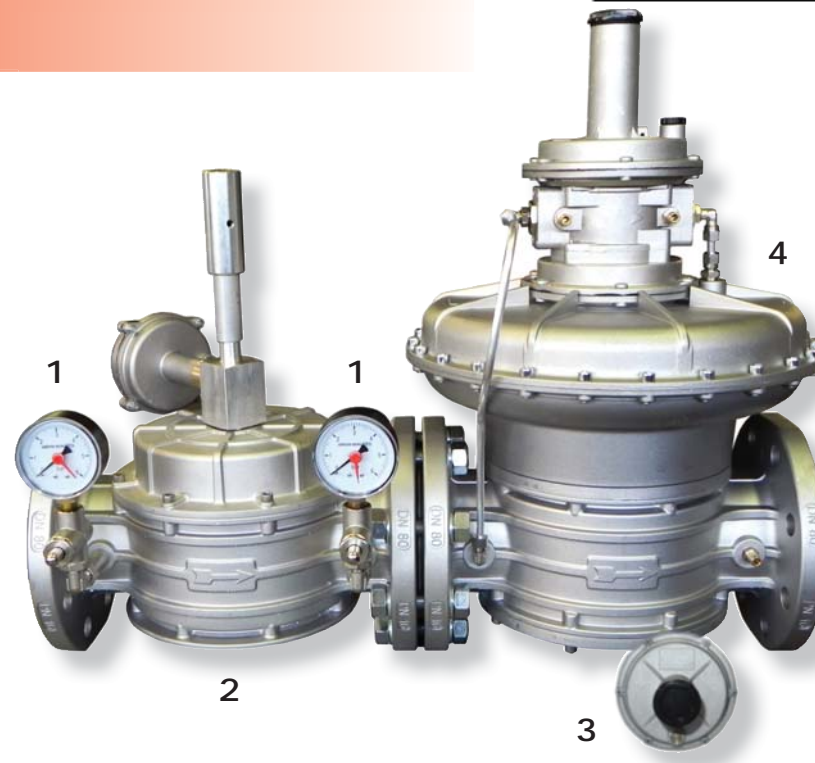

### LEGENDA:

1. MANOMETRO
2. VALVOLA DI BLOCCO
3. REGOLATORE DI PRESSIONE DN 50
4. VALVOLA DI SFIORO



### LEGEND:

1. PRESSURE GAUGE
2. OVER PRESSURE SLAM SHUT-OFF VALVE (OPSO)
3. GAS PRESSURE FILTER REGULATOR
4. RELIEF VALVE





## Gas Train DN 20



### LEGENDA:

1. FILTRO
2. VALVOLA A RIARMO N.C.
3. REGOLATORE DI PRESSIONE
4. MANOMETRO
5. ELETTROVALVOLA AUTOMATICA RAPIDA
6. PRESSOSTATO
7. ELETTROVALVOLA AUTOMATICA LENTA



### LEGEND:

1. GAS FILTER
2. NORMALLY-CLOSED MANUAL RESET SOLENOID VALVE
3. GAS PRESSURE REGULATOR
4. PRESSURE GAUGE
5. AUTOMATIC FAST OPENING SOLENOID VALVE
6. PRESSURE SWITCH
7. AUTOMATIC SLOW OPENING SOLENOID VALVE



## Gas Train DN 25



### LEGENDA:

1. FILTRO
2. VALVOLA A RIARMO N.C.
3. REGOLATORE DI PRESSIONE
4. MANOMETRO
5. ELETTROVALVOLA AUTOMATICA RAPIDA
6. PRESSOSTATO
7. ELETTROVALVOLA AUTOMATICA LENTA



### LEGEND:

1. GAS FILTER
2. NORMALLY-CLOSED MANUAL RESET SOLENOID VALVE
3. GAS PRESSURE REGULATOR
4. PRESSURE GAUGE
5. AUTOMATIC FAST OPENING SOLENOID VALVE
6. PRESSURE SWITCH
7. AUTOMATIC SLOW OPENING SOLENOID VALVE



## Gas Train DN 40

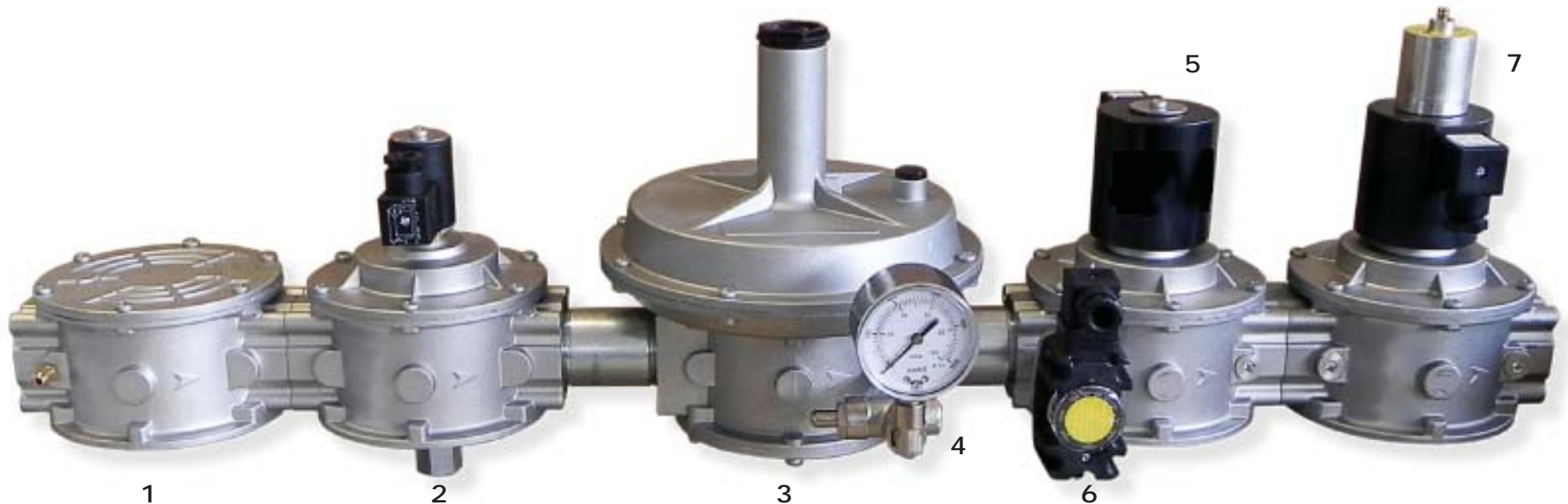

### LEGENDA:

1. FILTRO
2. VALVOLA A RIARMO N.C.
3. REGOLATORE DI PRESSIONE
4. MANOMETRO
5. ELETTROVALVOLA AUTOMATICA RAPIDA
6. PRESSOSTATO
7. ELETTROVALVOLA AUTOMATICA LENTA



### LEGEND:

1. GAS FILTER
2. NORMALLY-CLOSED MANUAL RESET SOLENOID VALVE
3. GAS PRESSURE REGULATOR
4. PRESSURE GAUGE
5. AUTOMATIC FAST OPENING SOLENOID VALVE
6. PRESSURE SWITCH
7. AUTOMATIC SLOW OPENING SOLENOID VALVE



## Gas Train DN 50

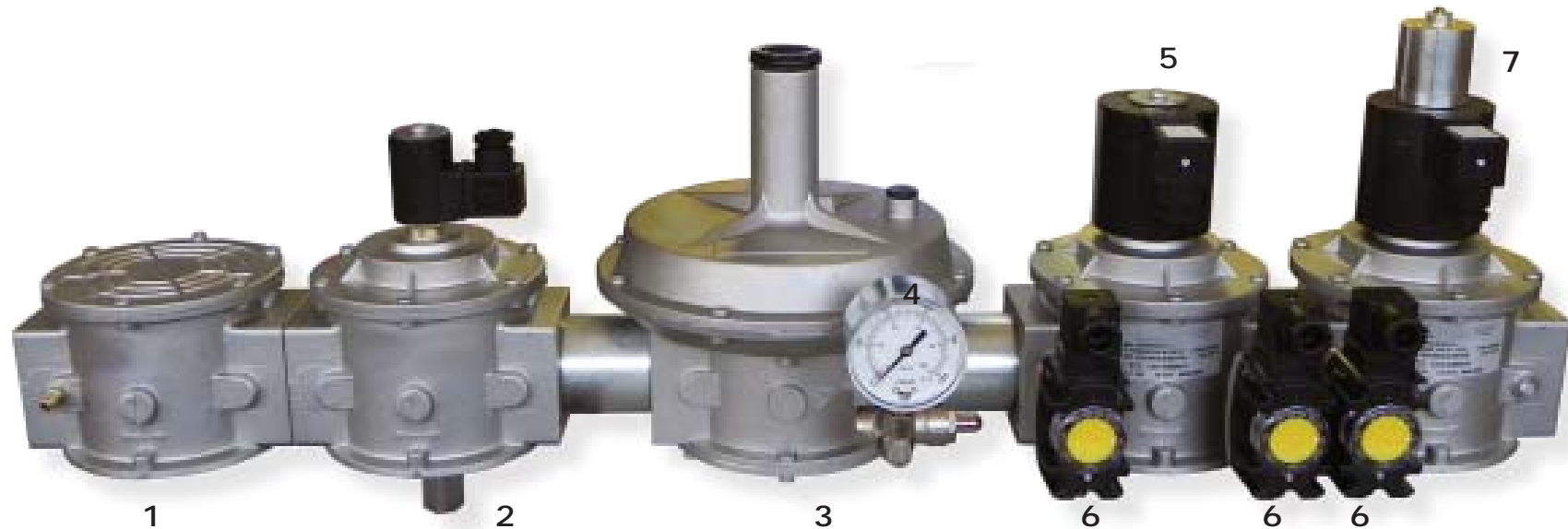

### LEGENDA:



1. FILTRO
2. VALVOLA A RIARMO N.C.
3. REGOLATORE DI PRESSIONE
4. MANOMETRO
5. ELETTROVALVOLA AUTOMATICA RAPIDA
6. PRESSOSTATO
7. ELETTROVALVOLA AUTOMATICA LENTA

### LEGEND:



1. GAS FILTER
2. NORMALLY-CLOSED MANUAL RESET SOLENOID VALVE
3. GAS PRESSURE REGULATOR
4. PRESSURE GAUGE
5. AUTOMATIC FAST OPENING SOLENOID VALVE
6. PRESSURE SWITCH
7. AUTOMATIC SLOW OPENING SOLENOID VALVE

## Gas Train DN 80

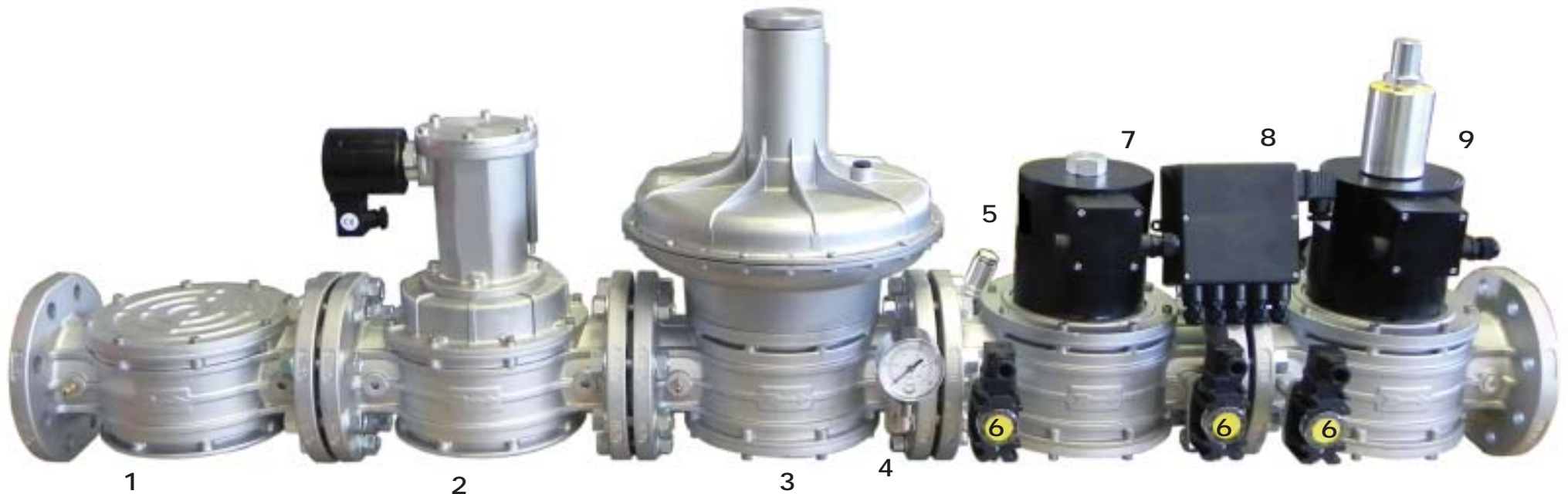

### LEGENDA:

1. FILTRO
2. VALVOLA A RIARMO N.C.
3. REGOLATORE DI PRESSIONE
4. MANOMETRO
5. VALVOLA DI SFIORO
6. PRESSOSTATO
7. ELETTROVALVOLA AUTOMATICA RAPIDA
8. CONTROLLO TENUTA VALVOLE
9. ELETTROVALVOLA AUTOMATICA LENTA



### LEGEND:

1. GAS FILTER
2. NORMALLY-CLOSED MANUAL RESET SOLENOID VALVE
3. GAS PRESSURE REGULATOR
4. PRESSURE GAUGE
5. RELIEF VALVE
6. VALVE PROVING SYSTEM
7. PRESSURE SWITCH
8. AUTOMATIC FAST OPENING SOLENOID VALVE
9. AUTOMATIC SLOW OPENING SOLENOID VALVE

