

# *BASKET TYPE SEPARATOR FILTER*

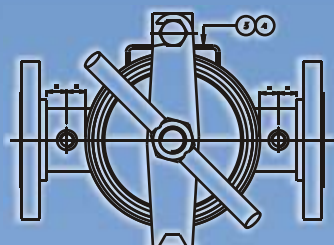
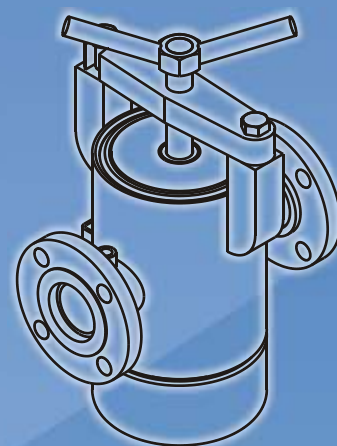
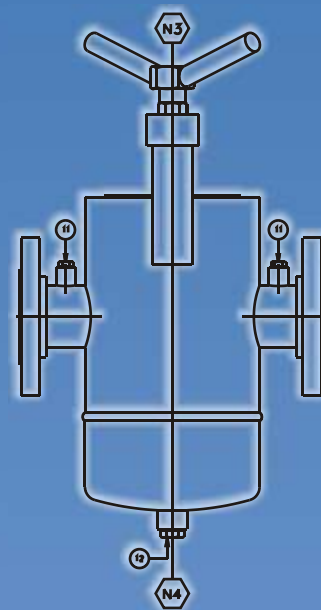
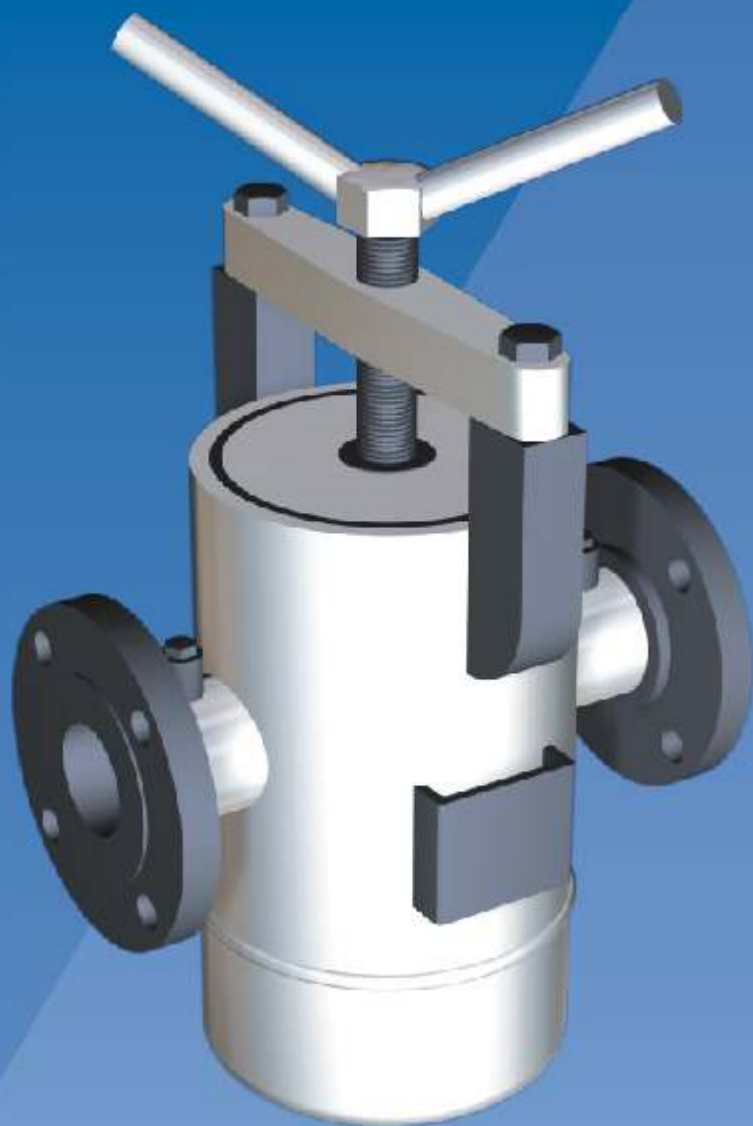

**GASCAT**

# BASKET FILTER SEPARATOR

## TYPICAL APPLICATIONS

- **Protection of Compressors**
- **Protection of Gas Turbines** - To avoid corrosion, erosion, impact, and adhesion of solids to the equipment internal components
- **Treatment of gas for instrumentation**
- **Pressure Reduction Stations (PRS)** - To protect the station, measurement and control equipment, besides assuring gas quality to the end user
- **In Drying Columns and Molecular Sieves** - To protect desiccants and sieve beds from solid contaminants generated in compressors
- **Efficient in removing black powder (oxides and sulfides) in piping (Particles > 20 m).**

## APPLICATIOnS

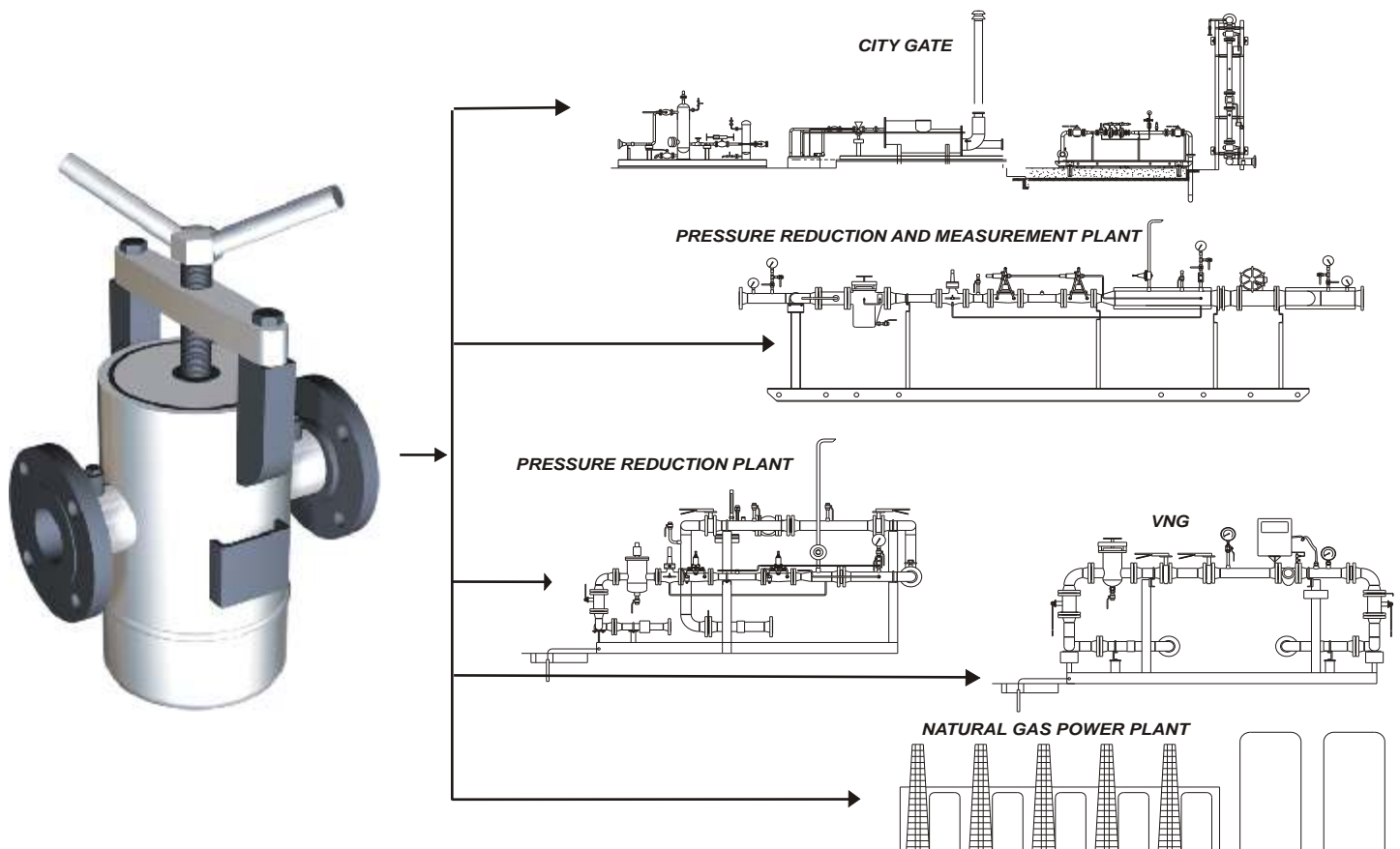

## MAIN ADVANTAGES OF GASCAT FILTERS

- Do not require special tools usage for maintenance
- Quick open and close system for easy access to filter inside
- Exclusively designed and manufactured it for use with **natural gas**
- Equipment entirely built at Gascat premises, under ISO 9000 certification
- Standardized dimensions facilitating substitution of already installed filters
- Filter elements in stock with of-the-shelf replacement
- Filtering element in 304 and 316 stainless steel mesh
- As an option, baskets can be supplied for high pressure drop
- Gascat has 22 years of experience in manufacturing and installation of equipment for use in the natural gas industry
- Technical support throughout Brazil by a staff of engineers and expert technicians
- Availability of a Training Center for training and qualifying our products' users

## DESCRIPTION

The Gascat basket type filter separators are designed for the filtration of solids from gas flows, using a metallic mesh basket, whose design and construction offers maximum filtering area and large capacity to hold and accumulate the filtered solids, while the basket outflow assures that all contaminants are retained in the filter. Of normalized construction it is compact and employs a fast opening system, that allows for a simple and easy change of the filtering element with no need for special tools. Operating with great efficiency and at pressure drop, they offer excellent protection for regulators and pressure gauges, minimizing maintenances and extending equipment useful life.



## FILTERING ELEMENTS

The Gascat basket type filter separators use standardized filtering elements, built in metallic stainless steel mesh and externally reinforced with a perforated stainless steel foil that provides excellent mechanical resistance to the basket. Optionally, the baskets can be built with the mesh in synthetic material.

A great advantage of the baskets is that the same can be cleaned and reused.

Gascat basket type filtering elements have nominal 20mm filtration degree and can be supplied flat or pleated, according to specific applications.

## BUILDING CHARACTERISTICS

- Designed and built according to ASME VIII Div I
- Building materials according to ASTM
- Pressure classes #150, #300 & #600 pounds (other values under request)
- Flanged connections ANSI B16.5 - 1" to 12" inches (other values under request)
- Quick open and close (QOC)
- Compact construction and simple operation
- Filters do not require special maintenance tools
- Filter operation from inside to outside of the element, therefore facilitating filtering action and element cleaning
- Baskets of standardized dimensions and immediate replacement
- 100% hydrostatically tested
- Standard mouthpieces orientation is in-line or 180° (other assemblies configurations under request)
- Painted and identified according to Gascat STD.

# BASKET FILTER SEPARATOR

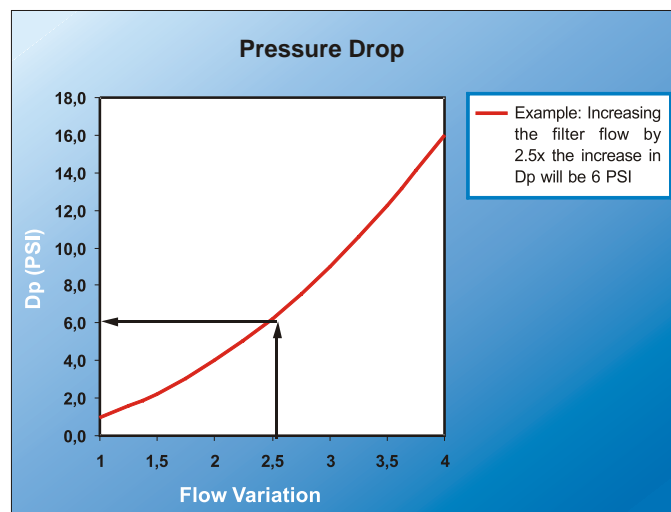
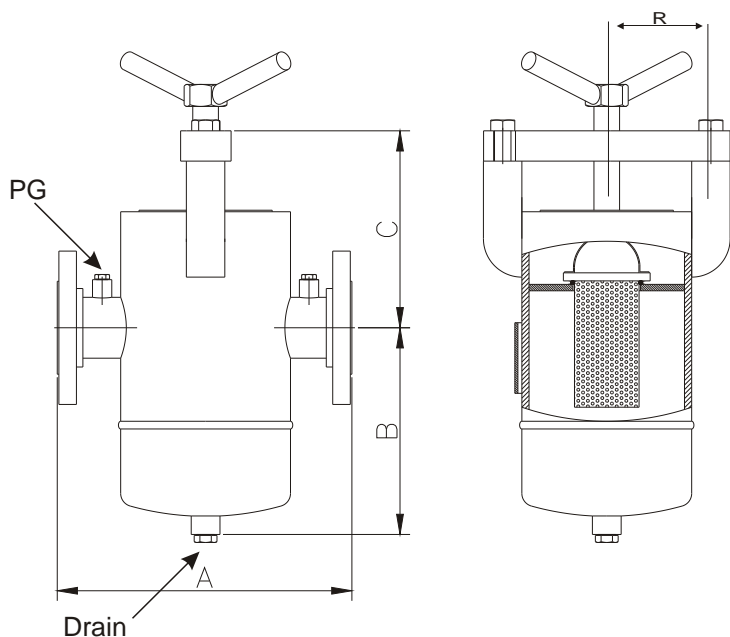

DIMENSIONS ( mm )																		
	150 #					300#					600#					FITTING		ELEMENT AREA
DN	A	B	C	D	R	A	B	C	D	R	A	B	C	D	R	DRAIN	TP	cm <sup>2</sup>
1	292	210	290	-	86	300	210	320	-	86	300	240	340	-	86	1/2	1/4	90
1.1/2	292	210	310	-	125	410	210	350	-	125	490	240	340	-	125	1/2	1/4	160
2	292	210	310	-	125	410	210	350	-	125	490	240	340	-	125	1/2	1/4	260
3	358	350	320	-	150	460	360	370	-	150	540	380	400	-	150	1	1/4	540
4	425	340	390	-	156	520	350	410	-	156	630	470	450	-	156	1	1/4	980
6	584	425	490	-	230	630	450	520	-	230	760	470	550	-	230	1	1/4	2060

**ABOVE 6" UNDER REQUEST**

**APPROXIMATE DIMENSIONS - FOR EXECUTIVE PROJECTS PLEASE REQUEST CERTIFIED DRAWINGS**

## Notes

- 1- Drain and pressure gauge connections are tapped for NPT 3000 #, optionally can be flanged.
- 2- Flanges for 150# filters are SORF type, but for 300#, 600#, and 900# classes are WNRF.
- 3- Longitudinal and circumferential welds are PL inspected for the 150# class, for other classes they are Xray and/or US inspected.
- 4- Optionally additional tests can be performed.
- 5- GASCAT filters are supplied packed in cardboard boxes or in wood crates.
- 6- Optionally can also be supplied differential pressure gauge meters, differential pressure switch, pressure transmitters, level transmitters, level viewfinder, and automatic purge drains.



### Head / Office Factory

Rodovia SP 73, nº 1141 - Bairro Pimenta

Indaiatuba - SP - CEP 13.347-390

Tel: (0 55 19) 3936-9300 - Fax: (0 55 19) 3935-6009

<http://www.gasc.com.br>

e-mail: [vendas@gasc.com.br](mailto:vendas@gasc.com.br)