

Serie IEL03...



DESCRIPTION

Single stage automatic normally closed solenoid valves that open when the coil is energized and close when there is no tension.

Pmax = 360 mbar

The solenoid valve can be controlled by pressure switch, thermostat, etc. They are equipped with a flow regulator and adjustable slow opening kit.

- EC certified according to EN 161
- In conformity with the 2009/142/EC Directive (Gas Directive)
- In conformity with the 94/9/EC Directive (ATEX Directive)
- In conformity with the 2004/108/EC Directive (Electromagnetic Compatibility)
- In conformity with the 2006/95/EC Directive (Low Voltage)

IDENTIFICATION

IEL S 03 02N 1 1 B

Gas automatic solenoid valve series IEL...

B = biogas

Types

- S = standard (fast opening)
- R = with flow regulation
- L1 = with adjustable slow opening + flow regulation + adjustable rapid stroke
- L2 = with adjustable slow opening + flow regulation
- L3 = with adjustable slow opening + adjustable rapid stroke
- L4 = with adjustable slow opening

CPI switch

- 0 = no CPI switch
- 1 = CPI switch (P.max ≤ 1 bar)
- 2 = CPI switch (P.max > 1 bar)

Pmax

03 = Pmax 360 mbar

Voltage

- 1 = 12 V/50 Hz
- 2 = 12 Vdc
- 3 = 24 V/50 Hz
- 4 = 24 Vdc
- 6 = 110 V/50-60 Hz with rectifier
- 8 = 230 V/50-60 Hz with rectifier

Connections

Threaded				Flanged			
Code	GAS	Code NPT	NPT	Code	PN 16	Code ANSI	ANSI PN 16
02	DN 15 (G 1/2")	02N	DN 15 (NPT 1/2")				
03	DN 20 (G 3/4")	03N	DN 20 (NPT 3/4")				
04	DN 25 (G 1")	04N	DN 25 (NPT 1")	25	DN 25	25A	DN 25 ANSI
05	DN 32 (G 1"1/4)	05N	DN 32 (NPT 1"1/4)	32	DN 32	32A	DN 32 ANSI
06	DN 40 (G 1"1/2)	06N	DN 40 (NPT 1"1/2)	40	DN 40	40A	DN 40 ANSI
07	DN 50 (G 2")	07N	DN 50 (NPT 2")	50	DN 50	50A	DN 50 ANSI
				08	DN 65	08A	DN 65 ANSI
				09	DN 80	09A	DN 80 ANSI
				10	DN 100	10A	DN 100 ANSI

**NOTE: not all combinations are possible
Please contact the technical department.**

GENERAL DATA

TECHNICAL DATA

- Use: not aggressive gases of the 3 families (dry gases)
- Threaded connections Rp: (DN 15 ÷ DN 50) according to EN 10226
- Flanged connections PN 16: (DN 25 ÷ DN 100) according to ISO 7005
- On request ANSI 150 flanged connections
- Power supply voltage: 12 Vdc, 12 V/50 Hz (only for DN 15-25)
24 Vdc, 24 V/50 Hz, 110 V/50-60 Hz, 230 V/50-60 Hz
- Power supply voltage tolerance: -15% ... +10%
- Power absorption: see coils and connector table
- Max. working pressure: 360 mbar
- Environment temperature: -15 ÷ +60 °C
- Max superficial temperature: 85 °C
- Protection degree: IP65
- Class: A
- Group: 2
- Closing time: <1 s
- Opening time: <1 s

Coils: polyammiac resin encapsulated with glass fibre, connection type DIN 43650; the insulation class is F (155°) and the enamelled copper wire class is H (180°). Coils (DN 32 ÷ DN 100): the insulation class and the enamelled copper wire class is H (180°).

MATERIALS

- Die-cast aluminium (UNI EN 1706)
- OT-58 brass (UNI EN 12164)
- 11S aluminium (UNI 9002-5)
- Galvanized and 430 F stainless steel (UNI EN 10088)
- NBR rubber (UNI 7702)
- Nylon 30% glass fibre (UNI EN ISO 11667)
- Viledon

COMPONENTS

fig. 1: DN 15
DN 20
DN 25

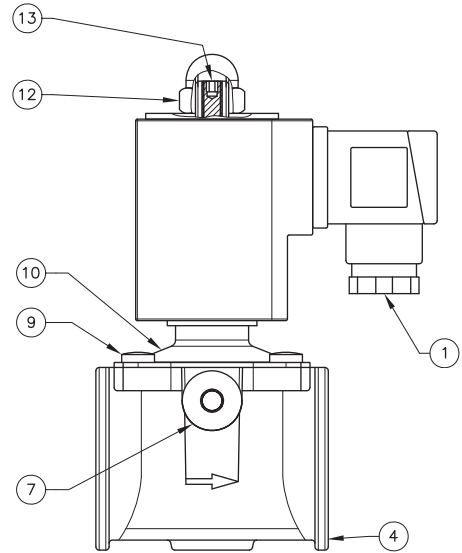
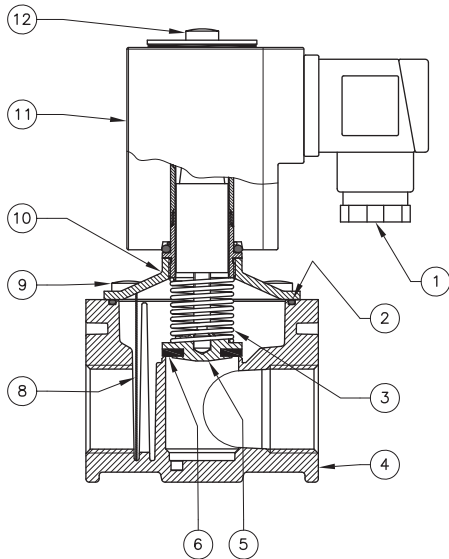

LEGEND

- | | |
|-------------------------|--|
| 1. Electrical connector | 8. Filter |
| 2. Seal O-Ring | 9. Cover fixing screws |
| 3. Closing spring | 10. Cover |
| 4. Valve body | 11. Electrical coil |
| 5. Closure member | 12. Coil fixing nut or screw |
| 6. Washer seal | 13. Flow calibration screw
(IELR version) |
| 7. G 1/4" cap | |

COMPONENTS

fig. 2: DN 32
DN 40
DN 50

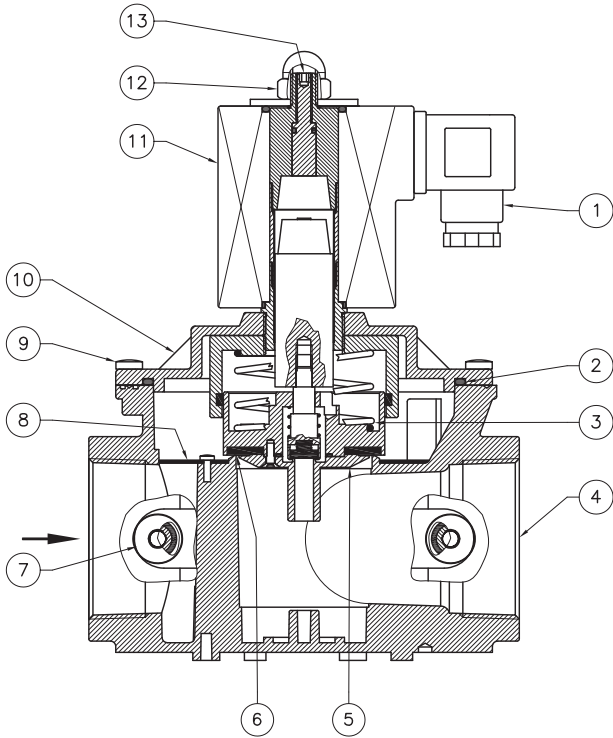

LEGEND

- | | |
|-------------------------|---|
| 1. Electrical connector | 8. Filter |
| 2. Seal O-Ring | 9. Fixing screws |
| 3. Closing spring | 10. Cover or bottom |
| 4. Valve body | 11. Electrical coil |
| 5. Closure member | 12. Coil fixing nut or screw |
| 6. Washer seal | 13. Flow calibration screw (IELR version) |
| 7. G 1/4" cap | 14. Bottom (only for DN 65-80-100) |

fig. 3: DN 65
DN 80
DN 100

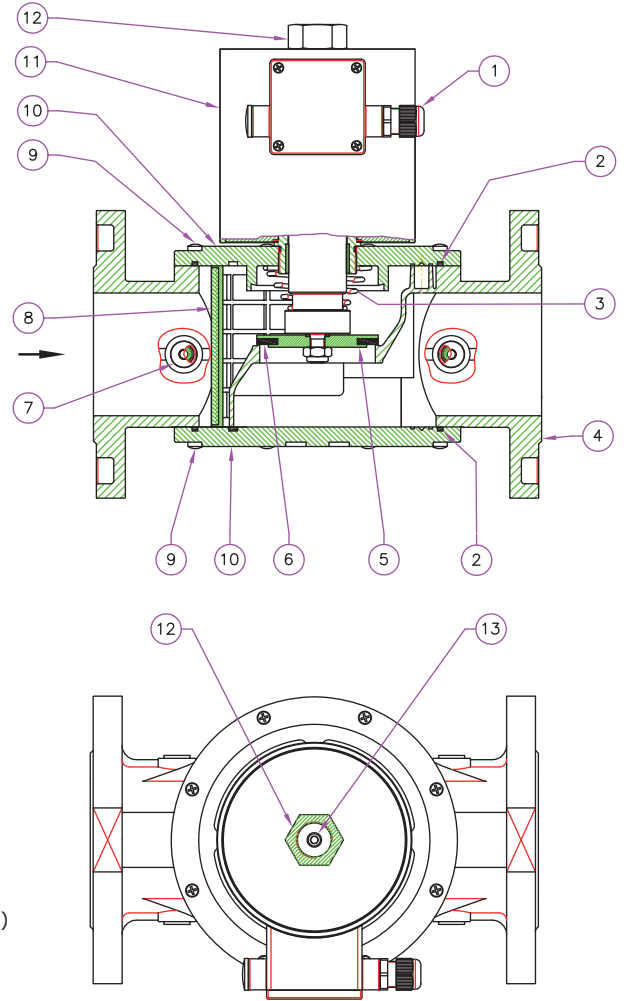
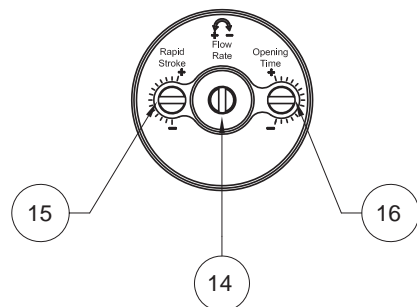
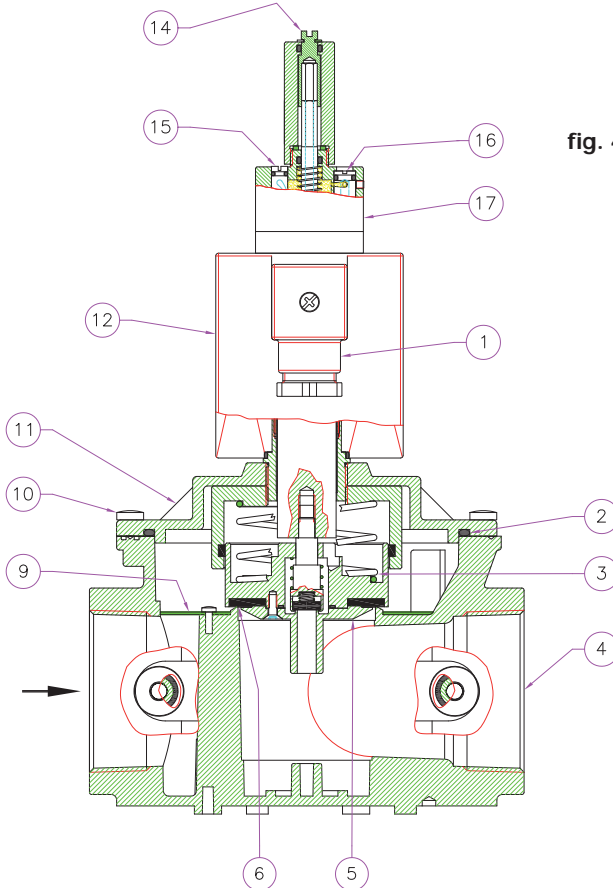

fig. 4: DN 15 - DN 100
with flow regulation

LEGEND

- | | |
|--------------------------|-------------------------------|
| 1 - Electrical connector | 10 - Cover fixing screws |
| 2 - Seal O-Ring | 11 - Cover |
| 3 - Closing spring | 12 - Electrical coil |
| 4 - Valve body | 14 - Flow calibration screw |
| 5 - Closure member | 15 - Rapid stroke calibration |
| 6 - Washer seal | 16 - Opening speed regulation |
| 9 - Filtering component | 17 - Slow opening kit |



PRESSURE DROP DIAGRAM

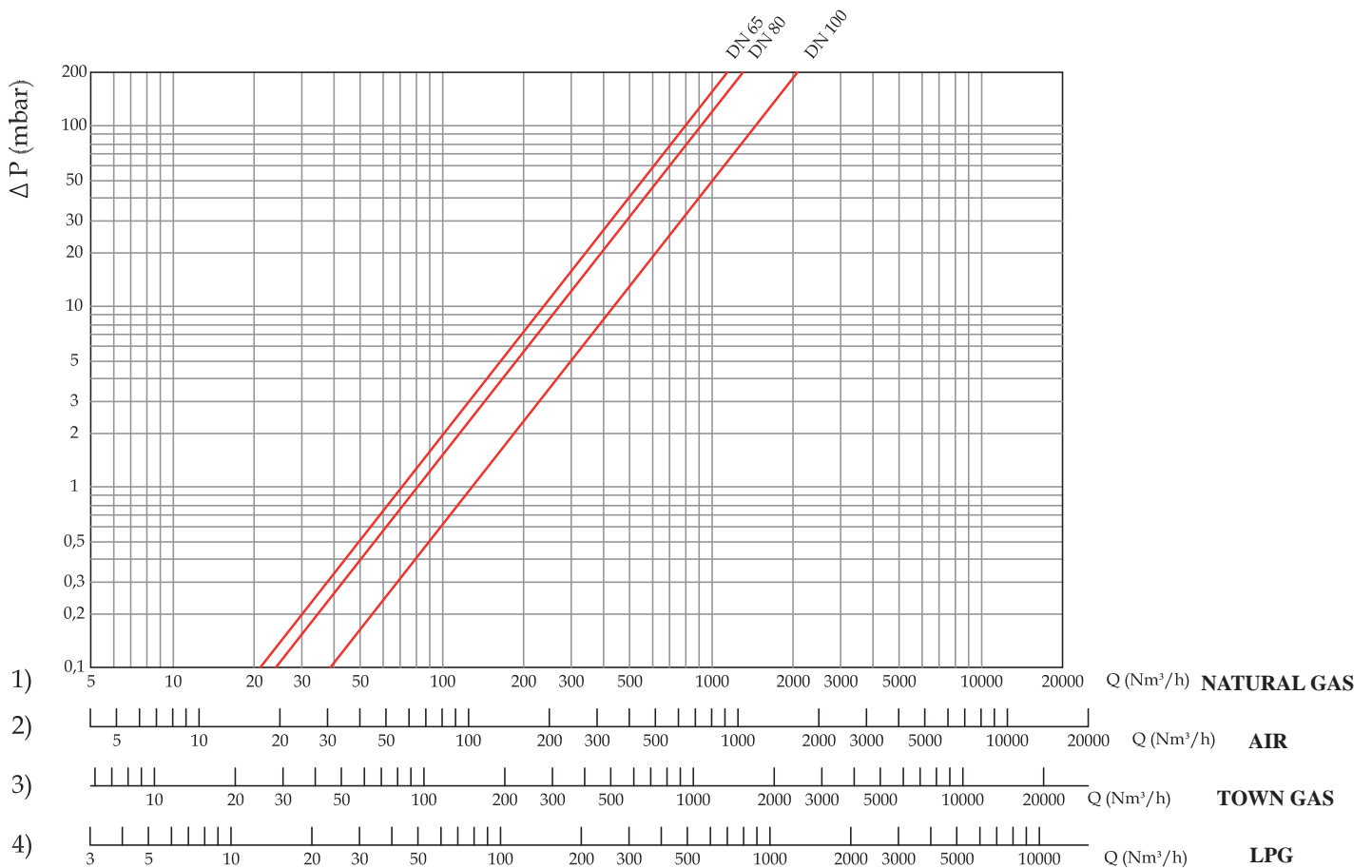
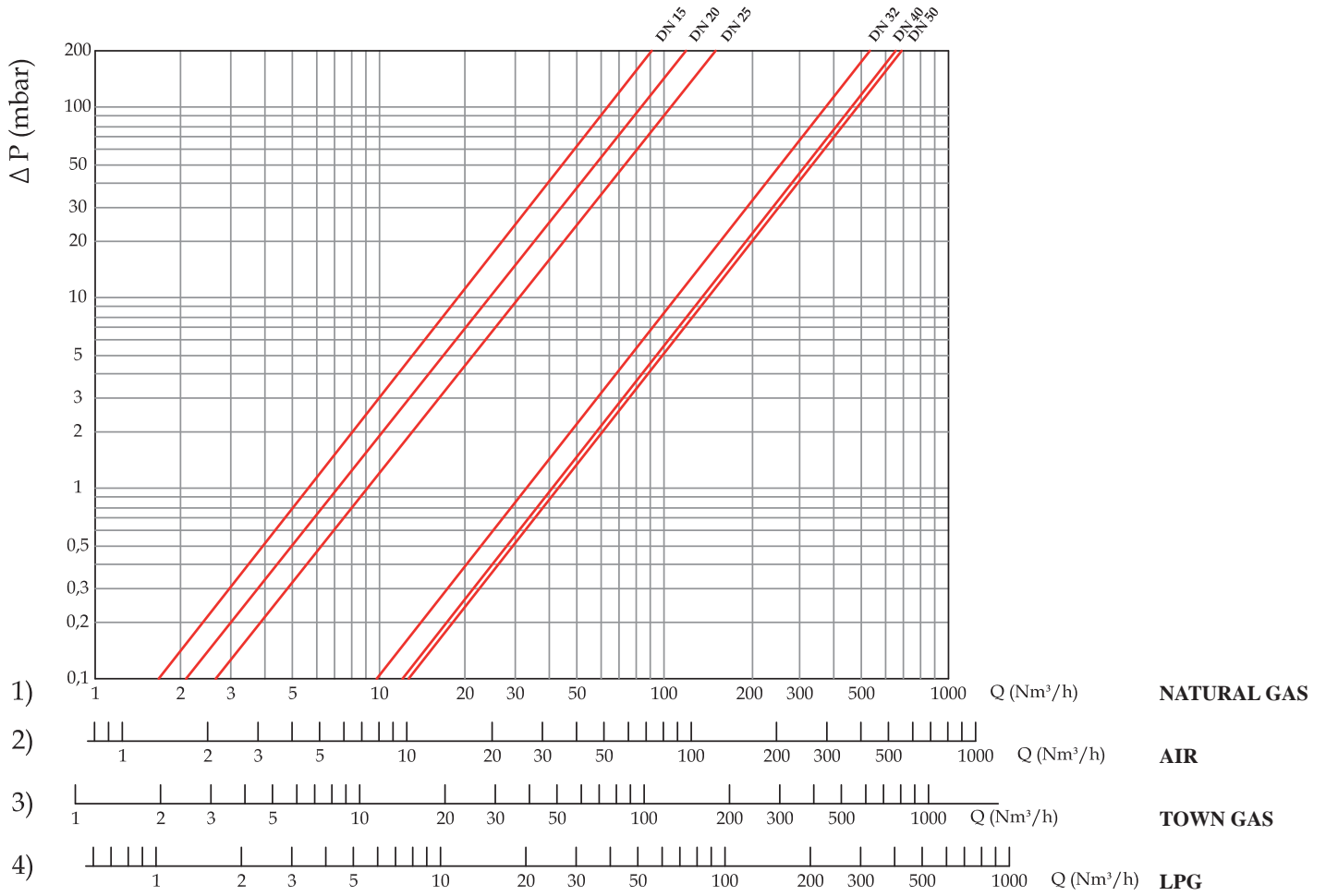

DIMENSIONS

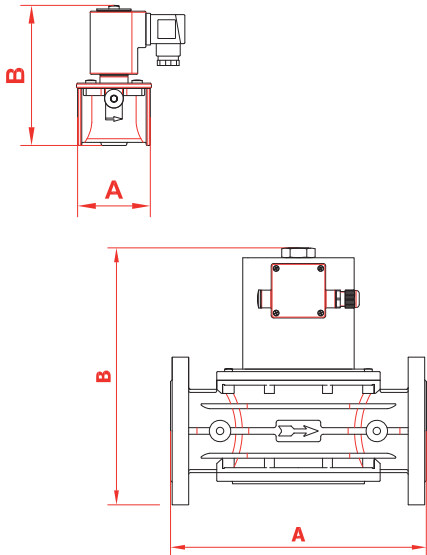

Threaded connections	Flanged connections	A	B		
			IELS...	IELR...	IELL...
DN 15 - DN 20	-	70	137	150	205
DN 25	-	70	137	150	205
-	DN 25	142	170	195	250
DN 32 - DN 40 - DN 50	-	160	210	225	290
-	DN 32 - DN 40 - DN 50	230	237	252	295
-	DN 65	290	321	321	480
-	DN 80	310	328	328	486
-	DN 100	350	389	389	547

COILS AND CONNECTORS

MODEL	TENSION	COIL CODE	COIL STAMPING	CONNECTOR CODE	ENERGY SAVING	POWWER ABSORPTION	MAX CYCLES/HOUR	MIN OFF TIME (s)
IELO3(L1-L2-L3-L4) DN 15 - DN 20 - DN 25	12 Vdc	BO-0407	BO-0407 12V RAC ES	CN-2101	YES	56 VA Energy saving 16 VA	50	2
	12 V/50 Hz	BO-0407	BO-0407 12V RAC ES	CN-2111	YES	56 VA Energy saving 16 VA	50	2
	24 Vdc	BO-0417	BO-0417 24V RAC ES	CN-2101	YES	56 VA Energy saving 16 VA	50	2
	24 V/50 Hz	BO-0417	BO-0417 24V RAC ES	CN-2111	YES	56 VA Energy saving 16 VA	50	2
	110 V/50-60 Hz	BO-0427	BO-0427 110V RAC ES	CN-2131	YES	63 VA Energy saving 20 VA	50	2
	230 V/50-60 Hz	BO-0437	BO-0437 230V RAC ES	CN-2131	YES	54 VA Energy saving 18 VA	50	2
IELO3(L1-L2-L3-L4) DN 32 - DN 40 - DN 50	24 Vdc	BO-0355	BO-0355 24 V RAC ES	CN-2101	YES	68 VA Energy saving 18 VA	50	2
	24 V/50 Hz	BO-0355	BO-0355 24 V RAC ES	CN-2111	YES	68 VA Energy saving 18 VA	50	2
	110 V/50-60 Hz	BO-0365	BO-0365 110 V RAC ES	CN-2131	YES	77 VA Energy saving 23 VA	50	2
	230 V/50-60 Hz	BO-0375	BO-0375 230 V RAC ES	CN-2131	YES	89 VA Energy saving 25 VA	50	2
IELO3(L1-L2-L3-L4) DN 32 FL - DN 40 FL - DN 50 FL	24 Vdc	BO-0355	BO-0355 24 V RAC ES	CN-2101	YES	68 VA Energy saving 18 VA	50	2
	24 V/50 Hz	BO-0355	BO-0355 24 V RAC ES	CN-2111	YES	68 VA Energy saving 18 VA	50	2
	110 V/50-60 Hz	BO-0365	BO-0365 110 V RAC ES	CN-2131	YES	77 VA Energy saving 23 VA	50	2
	230 V/50-60 Hz	BO-0375	BO-0375 230 V RAC ES	CN-2131	YES	89 VA Energy saving 25 VA	50	2
IELO3(L1-L2-L3-L4) DN 65 - DN 80	24 Vdc	BO-2110	24 Vdc DN 65 - 80	CN-2001	YES	185 VA Energy Saving 50 VA	35	5
	24 V/50 Hz	BO-2115	24 Vac DN 65 - 80	CN-2011	YES	185 VA Energy Saving 50 VA	35	5
	110 V/50-60 Hz	BO-2120	110 Vac DN 65 - 80	CN-2021	YES	260 VA Energy Saving 70 VA	35	5
	230 V/50-60 Hz	BO-2130	230 Vac DN 65 - 80	CN-2031	YES	290 VA Energy Saving 75 VA	35	5
IELO3(L1-L2-L3-L4) DN 100	24 Vdc	BO-2210	24 Vdc DN 100	CN-2001	YES	130 VA Energy Saving 40 VA	35	5
	24 V/50 Hz	BO-2215	24 Vac DN 100	CN-2011	YES	120 VA Energy Saving 35 VA	35	5
	110 V/50-60 Hz	BO-2220	110 Vac DN 100	CN-2021	YES	270 VA Energy Saving 70 VA	35	5
	230 V/50-60 Hz	BO-2230	230 Vac DN 100	CN-2031	YES	270 VA Energy Saving 70 VA	35	5

INSTALLATION

The solenoid valve is in conformity with the Directive 94/9/CE (Directive ATEX 100 a) as device of group II, category 3G and as device of group II, category 3D; for this reason it is suitable to be installed in the zones 2 and 22 as classified in the attachment I to the Directive 99/92/EC. The solenoid valve is not suitable to be used in zones 1 and 21 and, all the more so, in zones 0 and 20 as classified in the already said Directive 99/92/EC.

To determine the qualification and the extension of the dangerous zones, see the norm EN 60079-10.

The device, if installed and serviced respecting all the conditions and the technical instructions of this document, is not source of specific dangers: in particular, during the normal working, there is no emission in the atmosphere of inflammable substance in way to cause an explosive atmosphere.



Installation must be in compliance with local legislation in force!

**WARNING: Read carefully the instruction sheet of each product before installing.
Installation and maintenance operations must be carried out by qualified personnel.**

- The gas supply must be shut off before installation.
- Check that the line pressure **DOES NOT EXCEED** the maximum pressure stated on the product label.
- The device must be installed with the arrow (on the body of the device) facing towards the user appliance. They will function equally effectively if installed vertical. The device must not be installed upside down (with the coil underneath).
- During installation take care not to allow impurities or scraps of metal to enter the device.
- If the device is threaded check that the pipeline thread is not too long; overlong threads may damage the body of the device when screwed into place. Do not use the coil for leverage when screwing into position; use the appropriate tool.
- If the device is flanged check that the inlet and outlet counterflanges are perfectly parallel to avoid unnecessary mechanical stresses on the body of the device. Also calculate the space needed to fit the seal. If the gap left after the seal is fitted is too wide, do not try to close it by over-tightening the device's bolts.
- Always check that the system is gas-tight after installation.
- Unscrew the nut (12) and set the wanted value of the gas flow by the regulation screw (13). Then rescrew the nut (12) in the original position.

CALIBRATIONS

- To regulate the opening speed of the obturator operate on the screw (16). The opening speed increases gradually screwing clockwise the screw (16).
- To regulate the rapidity of the stroke operate on the screw (15). Screwing counterclockwise till the limit, the opening of the valve will be slow at first, screwing it clockwise you get a first phase of speed opening and a second slow one.
- To regulate the flow operate on the screw (14). Screwing it clockwise in order to decrease the flow, counterclockwise in order to increase it.
For connections \geq DN 65 in order to make this regulation you need at first to disconnect power to the coil. In this way you avoid the regulation screw to be submitted to useless mechanical efforts.

ELECTRICAL CONNECTIONS

- Before making electrical connections, check that the mains voltage is the same as the power supply voltage stated on the product label.
- Disconnect the power supply before wiring.
- Wire the connector with cable type: DN 15 ÷ DN 50
H05RN-F 3X0,75mm², Ø outside from 6,2 to 8,1 mm
DN 65 ÷ DN 100
H05RN-F 3X1 mm², Ø outside from 8,3 to 9,5 mm

Ensure that the device has IP65 protection.

- Connect the power supply to terminals 1 and 2 and the ground wire to terminal \perp .
IMPORTANT: with tension 12 Vdc and 24 Vdc with energy saving connector C21-23 observe the polarity.

The coil is also suitable for permanent power supply. In case of continuous duty, it is absolutely normal for the coil to heat up.

The coil should not be touched with bare hands after it has been continuously powered for more than 20 minutes. Before maintenance work, wait for the coil to cool or use suitable protective equipment.

EXAMPLE OF INSTALLATION

1. manual reset solenoid valve IENA
2. gas filter IF
3. filter regulator IFR
4. overflow valve
5. fast opening valve IEL
6. slow opening valve IEL
7. leak tester

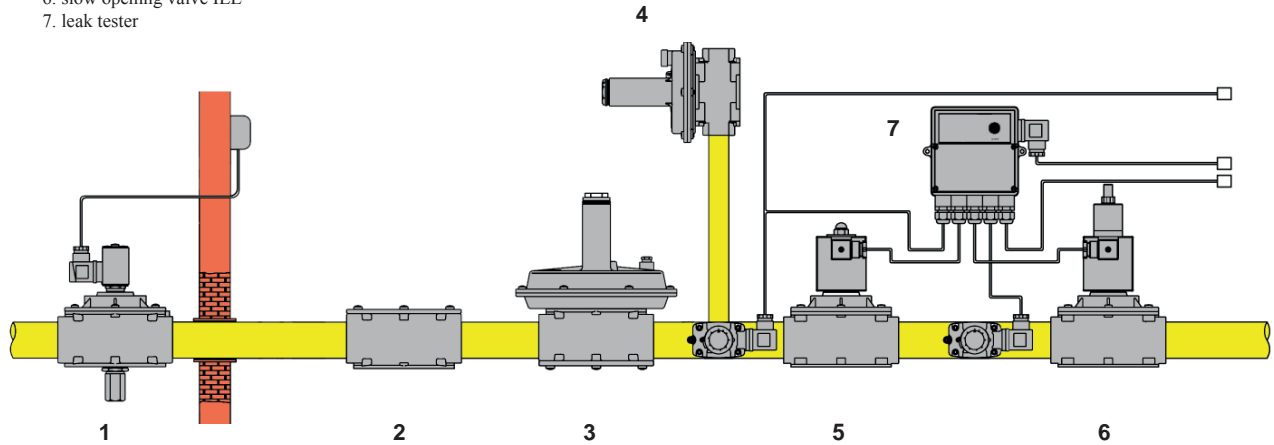

MAINTENANCE

Before performing any internal checks make sure that:

1. the power supply to the device is disconnected
2. there is no pressurised gas inside the device

- **DN 15 ÷ DN 25:** (see fig. 1) unscrew the coil fixing screws (12) and remove the coil (11). Unscrew the cover fixing screws (9) and disassemble it from body valve (4). Check the closure member (5), clean or if is necessary substitute the rubber made seal component. Clean the filter (8) blowing it without taking it off the body valve (4). Then assemble doing backward the same operation of dismantling.
- **DN 32 ÷ DN 100:** (see fig. 2 and 3) unscrew the nut (12) (or the slow opening kit (17)) and remove the coil (11). Unscrew the fixing screws (9) and, with care, take the cover (10) off the body (4) of the valve, then control the closure member (5) and if it is necessary change the rubber made seal component (6). Then clean or blow the filter (8) or change it if necessary; then assemble doing backward the same operation.



All operations must be carried out only by qualified personnel.

VIEW: BODY OF THE VALVE WITHOUT COVER

TO INSERT THE NET

DN 32 ÷ DN 50: Position it as in the figure taking care to respect the guides in the internal circumference of the body valve and fix it by the three special screws (M3x10).

TO INSERT THE FILTERING ORGAN:

DN 65 ÷ DN 100: Position it as in the figure taking care to put it inside the guides (18).

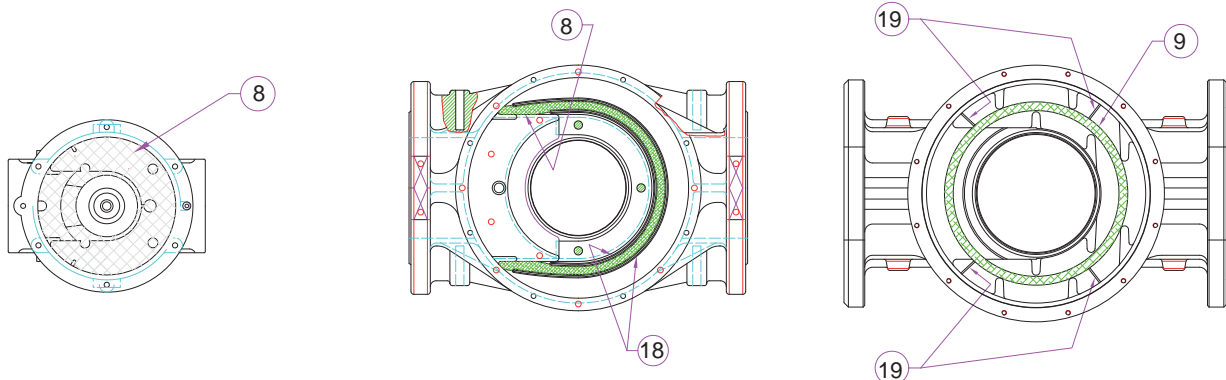

FOR FURTHER INFORMATION PLEASE CONTACT OUR TECHNICAL OFFICE.

