

Serie IR1/2...



CHARACTERISTICS

Gas pressure closing regulator

Pmax = 1 bar
Pmax = 2 bar

ITALPUMP series IR is a gas pressure regulator device adjustable screw which grant a reliable regulation of out put pressure, working principle is based on composition of 3 forces:

1. regulation screw
2. differential pressure working diaphragm
3. downstream pressure

- EC certified according to EN 88-2
- In conformity with the 2009/142/EC Directive (Gas Directive)
- In conformity with the 2014/68/EU Directive (PED Directive)
- In conformity with the 2014/34/EU Directive (ATEX Directive)

IDENTIFICATION

IR 1 02N 017 A B

Gas pressure closing regulator **series IR...**

Pmax
1 = Pmax 0,5 ÷ 1 bar
2 = Pmax 1 ÷ 2 bar

B = biogas

Versions

A = P2 > 200 mbar (strengthen diaphragm)

Settings: see next page

017 = spring setting (mbar)

023 = spring setting (mbar)

.....

Connections

Threaded				Flanged			
Code	GAS	Code NPT	NPT	Code	PN 16	Code ANSI	ANSI PN 16
02	DN 15 (G 1/2")	02N	DN 15 (NPT 1/2")				
03	DN 20 (G 3/4")	03N	DN 20 (NPT 3/4")				
04	DN 25 (G 1")	04N	DN 25 (NPT 1")	25	DN 25	25A	DN 25 ANSI
05	DN 32 (G 1"1/4)	05N	DN 32 (NPT 1"1/4)	32	DN 32	32A	DN 32 ANSI
06	DN 40 (G 1"1/2)	06N	DN 40 (NPT 1"1/2)	40	DN 40	40A	DN 40 ANSI
07	DN 50 (G 2")	07N	DN 50 (NPT 2")	50	DN 50	50A	DN 50 ANSI
				08	DN 65	08A	DN 65 ANSI
				09	DN 80	09A	DN 80 ANSI
				10	DN 100	10A	DN 100 ANSI

**NOTE: not all combinations are possible
Please contact the technical department.**

Versions with threaded connections

Connections	Setting (mbar)	P. max 0,5 ÷ 1 bar	P. max 1 ÷ 2 bar
		Code	Code
DN 15	10 ÷ 28	017	-
	9 ÷ 22	-	016
	18 ÷ 40	023	-
	20 ÷ 40	-	023
	40 ÷ 110	032	032
	110 ÷ 150	036	036
	150 ÷ 200	037	037
	200 ÷ 600	046	046
DN 20	10 ÷ 28	017	-
	9 ÷ 22	-	016
	18 ÷ 40	023	-
	20 ÷ 40	-	023
	40 ÷ 110	032	032
	110 ÷ 150	036	036
	150 ÷ 200	037	037
	200 ÷ 600	046	046
DN 25	10 ÷ 28	017	-
	9 ÷ 22	-	016
	18 ÷ 40	023	-
	20 ÷ 40	-	023
	40 ÷ 110	032	032
	110 ÷ 150	036	036
DN 32	13 ÷ 23	031	-
	12 ÷ 35	-	032
	20 ÷ 36	033	-
	30 ÷ 50	-	036
	33 ÷ 58	037	-
	40 ÷ 60	-	037
	55 ÷ 100	041	-
	60 ÷ 95	-	041
	90 ÷ 190	048	048
	190 ÷ 500*	058	059
DN 40	13 ÷ 23	031	-
	12 ÷ 35	-	032
	20 ÷ 36	033	-
	30 ÷ 50	-	036
	33 ÷ 58	037	-
	40 ÷ 60	-	037
	55 ÷ 100	041	-
	60 ÷ 95	-	041
	90 ÷ 190	048	048
	190 ÷ 500*	058	059
DN 50	13 ÷ 23	031	-
	12 ÷ 35	-	032
	20 ÷ 36	033	-
	30 ÷ 50	-	036
	33 ÷ 58	037	-
	40 ÷ 60	-	037
	55 ÷ 100	041	-
	60 ÷ 95	-	041
	90 ÷ 190	048	048
	190 ÷ 500*	058	059

Versions with flanged connections

Connections	Setting (mbar)	P. max 0,5 ÷ 1 bar	P. max 1 ÷ 2 bar
		Code	Code
DN 25	10 ÷ 28	017	-
	9 ÷ 22	-	016
	18 ÷ 40	023	-
	20 ÷ 40	-	023
	40 ÷ 110	032	032
	110 ÷ 150	036	036
	150 ÷ 200	037	037
	200 ÷ 600	046	046
DN 32	13 ÷ 23	031	-
	12 ÷ 35	-	032
	20 ÷ 36	033	-
	30 ÷ 50	-	036
	33 ÷ 58	037	-
	40 ÷ 60	-	037
	55 ÷ 100	041	-
	60 ÷ 95	-	041
	90 ÷ 190	048	048
	190 ÷ 500*	058	059
DN 40	13 ÷ 23	031	-
	12 ÷ 35	-	032
	20 ÷ 36	033	-
	30 ÷ 50	-	036
	33 ÷ 58	037	-
	40 ÷ 60	-	037
	55 ÷ 100	041	-
	60 ÷ 95	-	041
	90 ÷ 190	048	048
	190 ÷ 500*	058	059
DN 50	13 ÷ 23	031	-
	12 ÷ 35	-	032
	20 ÷ 36	033	-
	30 ÷ 50	-	036
	33 ÷ 58	037	-
	40 ÷ 60	-	037
	55 ÷ 100	041	-
	60 ÷ 95	-	041
	90 ÷ 190	048	048
	190 ÷ 500*	058	059
DN 65	7 ÷ 18	042	042
	13 ÷ 27	043	043
	22 ÷ 58	044	044
	50 ÷ 130	049	049
	110 ÷ 200	602 (037+046)	602 (037+046)
DN 80	7 ÷ 18	042	042
	13 ÷ 27	043	043
	22 ÷ 58	044	044
	50 ÷ 130	049	049
	110 ÷ 200	602 (037+046)	602 (037+046)
DN 100	7 ÷ 16	042	042
	15 ÷ 27	043	043
	27 ÷ 55	044	044
	55 ÷ 130	049	049
	130 ÷ 200	602 (037+046)	602 (037+046)

Versions with P2 = 200-600 mbar

Connections	Setting (mbar)	P. max 0,5 ÷ 1 bar	P. max 1 ÷ 2 bar
		Code	Code
DN 65	200 ÷ 600*	046*	046*
DN 80	200 ÷ 600*	046*	046*
DN 100	200 ÷ 600*	046*	046*

* = strengthen diaphragm

GENERAL DATA

TECHNICAL DATA

- Use: not aggressive gases of the 3 families (dry gases)
- Threaded connections Rp: (DN 15 ÷ DN 50) according to EN 10226
- Flanged connections PN 16: (DN 25 ÷ DN 100) according to ISO 7005
- On request ANSI 150 flanged connections
- Max. working pressure: 0,5 bar
- Environment temperature: -15 ÷ +60 °C
- Max superficial temperature: 60 °C
- Class: A
- Group: 2
- Filtration: 50 µm (on request other)
- Filtration class: G 2 (according to EN 779)

MATERIALS

- Die-cast aluminium (UNI EN 1706)
- OT-58 brass (UNI EN 12164)
- 11S aluminium (UNI 9002-5)
- Galvanized and 430 F stainless steel (UNI EN 10088)
- NBR rubber (UNI 7702)
- Nylon 30% glass fibre (UNI EN ISO 11667)
- Viledon

DIMENSIONS

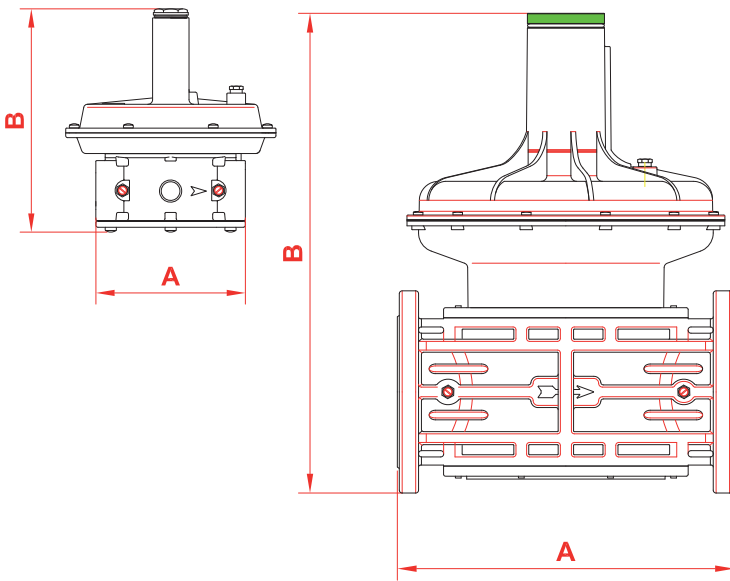

Connections	A	B	Weight (Kg)	Filtering area (mm ²)
DN 15	120	194	1,3	2810
DN 20	120	194	1,3	2810
DN 25	120	194	1,3	2810
DN 32	160	245	3,2	16800
DN 40	160	245	3,2	16800
DN 50	160	245	3,2	16800
DN 65	290	465	12,1	39240
DN 80	310	472	12,5	39240
DN 100	350	504	17,7	76250

**Versions (DN 25 - DN 32 - DN 40 - DN 50)
with flanged connections**

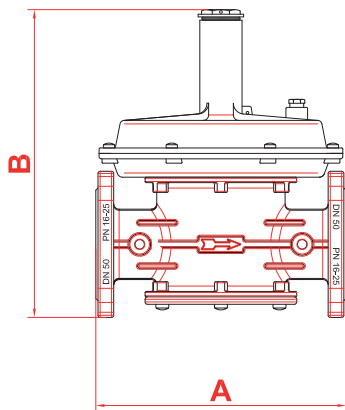

Connections	A	B	Weight (Kg)
DN 25	192	225	4
DN 32	230	285	4,5
DN 40	230	285	4,5
DN 50	230	285	4,5

Versions with P2 = 200÷600 mbar

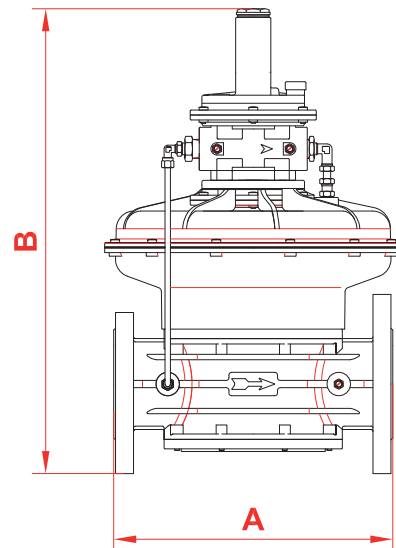

Connections	A	B	Weight (Kg)	Filtering area (mm ²)
DN 65	290	518	12,8	39240
DN 80	310	525	13	39240
DN 100	350	551	18,2	76250

COMPONENTS

fig. 1: DN 15
DN 20
DN 25

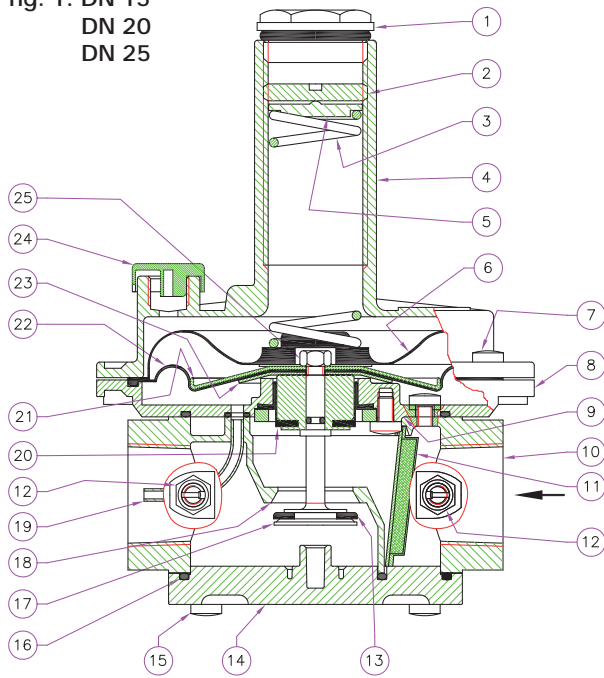
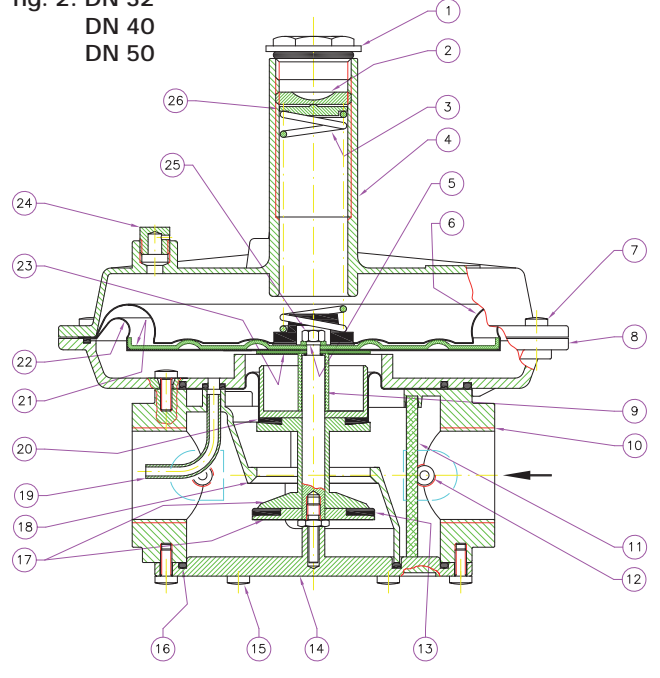

fig. 2: DN 32
DN 40
DN 50



- LEGEND**
- | | | | | |
|----------------------|--------------------------|---------------------------|-----------------------------|------------------------|
| 1 - Aluminium cap | 7 - Funnel fixing screws | 13 - Washer seal | 19 - Sensor tube | 25 - Central nut |
| 2 - Regulation screw | 8 - Flange | 14 - Bottom | 20 - Compensation diaphragm | 26 - Washer for spring |
| 3 - Setting spring | 9 - Central pin | 15 - Bottom fixing screws | 21 - Diaphragm upper disc | |
| 4 - Funnel | 10 - Body | 16 - Bottom seal O-Ring | 22 - Working diaphragm | |
| 5 - Toothed washer | 11 - Filtering organ | 17 - Closure member | 23 - Diaphragm lower disc | |
| 6 - Safety diaphragm | 12 - Pressure tap | 18 - Seal seat | 24 - Antidust cap | |

fig. 3: DN 65
DN 80
DN 100

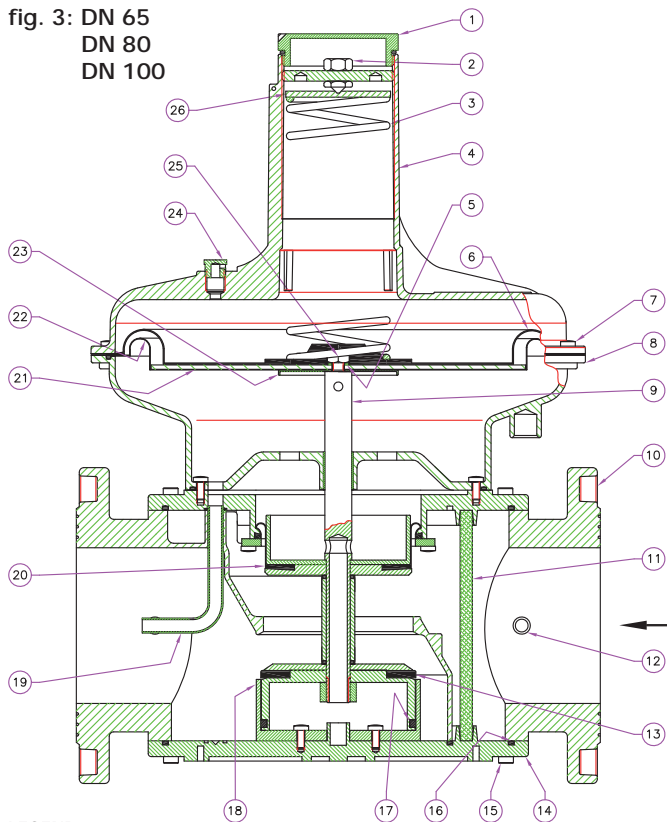
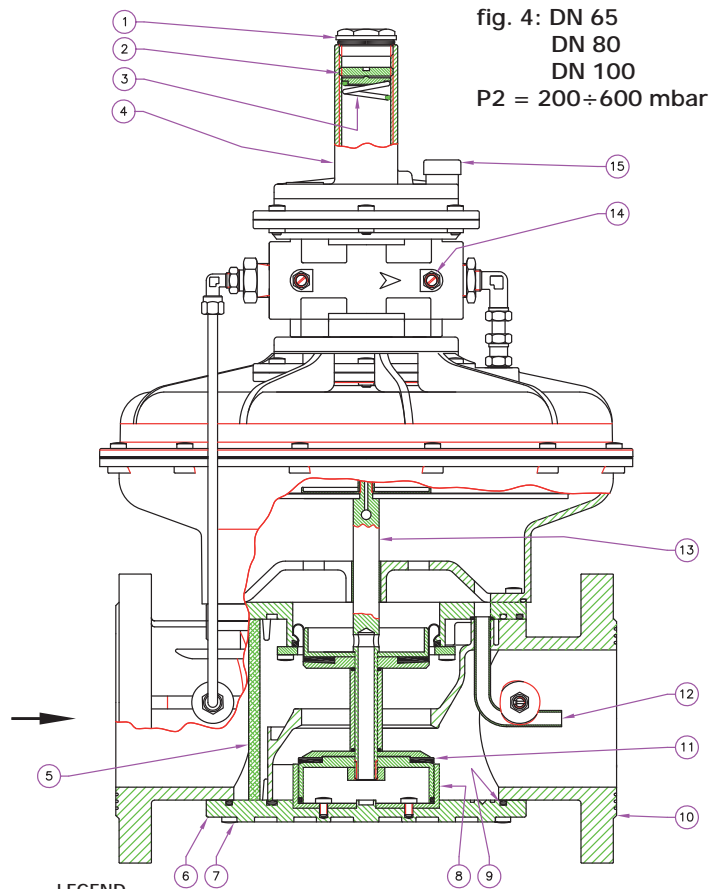
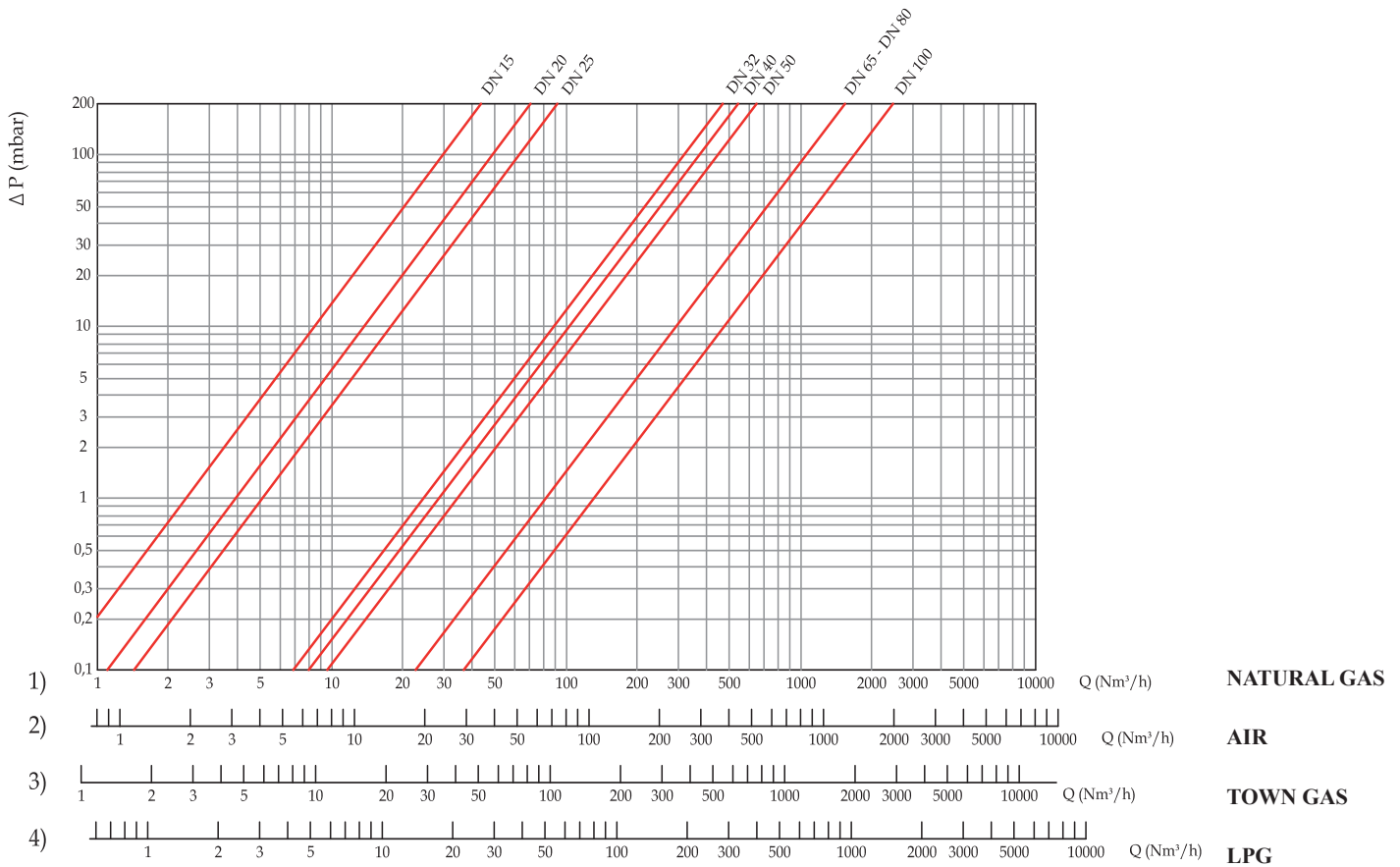

fig. 4: DN 65
DN 80
DN 100
P2 = 200÷600 mbar



- LEGEND**
- | | | |
|--------------------------|-----------------------------|--------------------------|
| 1 - Aluminium cap | 14 - Bottom | 9 - Washer seal |
| 2 - Regulation screw | 15 - Bottom fixing screws | 10 - Obturator guide |
| 3 - Setting spring | 16 - Bottom seal O-Ring | 3 - Funnel |
| 4 - Funnel | 17 - Teflon ring | 4 - Setting spring |
| 5 - Toothed washer | 18 - Closure member | 5 - Body |
| 6 - Safety diaphragm | 19 - Sensor tube | 6 - Filtering organ |
| 7 - Funnel fixing screws | 20 - Compensation diaphragm | 7 - Bottom |
| 8 - Flange | 21 - Diaphragm upper disc | 8 - Bottom fixing screws |
| 9 - Central pin | 22 - Working diaphragm | |
| 10 - Body | 23 - Diaphragm lower disc | |
| 11 - Filtering organ | 24 - Antidust cap | |
| 12 - Pressure tap | 25 - Central nut | |
| 13 - Washer seal | 26 - Washer for spring | |

PRESSURE DROP DIAGRAM



REGULATION SPRINGS DATA

CONNECTIONS	SETTING (mbar) <small>* with reinforced diaphragm (fig. 4)</small>	SPRING CODE	DIMENSIONS (mm) (d x De x Lo x it)	CONNECTIONS	SETTING (mbar) <small>* with reinforced diaphragm (fig. 4)</small>	SPRING CODE	DIMENSIONS (mm) (d x De x Lo x it)	
DN 15 ÷ DN 25	10 ÷ 28 (P. max 0,5÷1 bar)	017	1,5x29x85x10	DN 65 - DN 80	7 ÷ 18	042	4x66,5x155x16	
	18 ÷ 40 (P. max 0,5÷1 bar)	023	1,6x29x115x12		13 ÷ 27	043	4,5x70x200x14,5	
	9 ÷ 22 (P. max 1÷2 bar)	016	1,5x29x100x12		22 ÷ 50	044	5x70x200x13,5	
	20 ÷ 40 (P. max 1÷2 bar)	023	1,6x29x115x12		50 ÷ 130	049	6x70x200x10,5	
	40 ÷ 110	032	2,2x29x100x12		110 ÷ 200	049 + 050	6x70x200x10,5 + 5,5x54,5x195x12,5	
	110 ÷ 150	036	2,5x29x140x18,5		200 ÷ 600*	046	3,5x29,8x98x11,5	
	150 ÷ 200	037	2,5x29x155x16		DN 100	7 ÷ 16	042	4x66,5x155x16
	200 ÷ 600	046	3,5x29,8x98x11,5			15 ÷ 27	043	4,5x70x200x14,5
DN 32 ÷ DN 50	13 ÷ 23 (P. max 0,5÷1 bar)	031	2x29x140x16	27 ÷ 55		044	5x70x200x13,5	
	12 ÷ 35 (P. max 1÷2 bar)	032	2,2x29x100x12	55 ÷ 130		049	6x70x200x10,5	
	20 ÷ 36 (P. max 0,5÷1 bar)	033	2,2x29x140x18	130 ÷ 200		049 + 050	6x70x200x10,5 + 5,5x54,5x195x12,5	
	30 ÷ 50 (P. max 1÷2 bar)	036	2,5x29x140x18,5	200 ÷ 600*		046	3,5x29,8x98x11,5	
	33 ÷ 58 (P. max 0,5÷1 bar)	037	2,5x29x155x16	<div style="display: flex; align-items: center;"> <div style="margin-right: 20px;"> <p>Dimension Legend</p> <p>d=diameter</p> <p>De = external diameter</p> <p>Lo= length</p> <p>it = total number of turns</p> </div> </div>				
	40 ÷ 60 (P. max 1÷2 bar)	037	2,5x29x155x16					
	55 ÷ 100 (P. max 0,5÷1 bar)	041	3x29x140x18					
	60 ÷ 95 (P. max 1÷2 bar)	041	3x29x140x18					
	90 ÷ 190	048	3,5x29x125x14					
	190 ÷ 500* (P. max 0,5÷1 bar)	058	3,5x29,8x98x11,5					
	190 ÷ 500* (P. max 1÷2 bar)	059	3,5x29,8x98x11,5					

INSTALLATION

The regulator is in conformity with the Directive 2014/34/EU as device of group II, category 2G and as device of group II, category 2D; for this reason it is suitable to be installed in the zones 1 and 21 (besides in the zones 2 and 22) as classified in the attachment I to the Directive 99/92/EC.

The regulator is not suitable to be used in zones 0 and 20 as classified in the already said Directive 99/92/EC.

To determine the qualification and the extension of the dangerous zones, see the norm CEI EN 60079-10-1.

The device, if installed and serviced respecting all the conditions and the technical instructions of this document, is not source of specific dangers: in particular, there is no emission in the atmosphere of inflammable substance only occasionally.

The regulator can be dangerous as regards to the presence close to it of other devices only in case of damage either of the working diaphragm or of the safety one: only in this case the regulator is a source of emission of the continue degree explosive atmosphere and, so, it can originate dangerous areas 0 as defined in the 99/92/EC Directive.

In conditions of particularly critic installation (places not protected, lack of servicing, lacking availability of ventilation) and, especially in presence, close to the regulator, of potential sources of primer and/or dangerous devices during the normal working because susceptible to origine electric arcs or sparks, it is necessary to value before the compatibility between the regulator and these devices.

In any case it is necessary to take any useful precaution to avoid that the regulator could be origin of areas 0: for example yearly periodical inspection of regular working, possibility to change the emission degree of the source or to attend on the exhaust outside the explosive material.

For this, it is possible to connect the threaded hole G 1/4" outside by a copper pipe removing the anti-dust cap (fig. 1, 2 and 3 (24), fig. 4 (15)).



Installation must be in compliance with local legislation in force!

**WARNING: Read carefully the instruction sheet of each product before installing.
Installation and maintenance operations must be carried out by qualified personnel.**

- The gas supply must be shut off before installation.
- Check that the line pressure **DOES NOT EXCEED** the maximum pressure stated on the product label.
- The regulator is normally installed before the user. It must be installed with the arrow on the body (10) towards the user.
- It can be installed in any position but it is preferable the installation with the spring (3) in vertical position (see fig. 1, 2 and 3). Outside the regulator, downstream of it, there is a checking pressure-tap for the control of the regulation pressure.
- During installation take care not to allow debris or scraps of metal to enter the device.
- If the device is threaded check that the pipeline thread is not too long; overlong threads may damage the body of the device when screwed into place.
- Do not use the spring casing for leverage when screwing into place; use the appropriate tool.
- If the device is flanged check that the inlet and outlet counterflanges are perfectly parallel to avoid unnecessary mechanical stresses on the body of the device. Also calculate the space needed to fit the seal. If the gap left after the seal is fitted is too wide, do not try to close it by over-tightening the device's bolts.
- Always check that the system is gas-tight after installation.

EXAMPLE OF INSTALLATION

1. gas filter IF
2. filter regulator IFR
3. fast opening valve IEL
4. slow opening valve IEL
5. overflow valve
6. leak tester

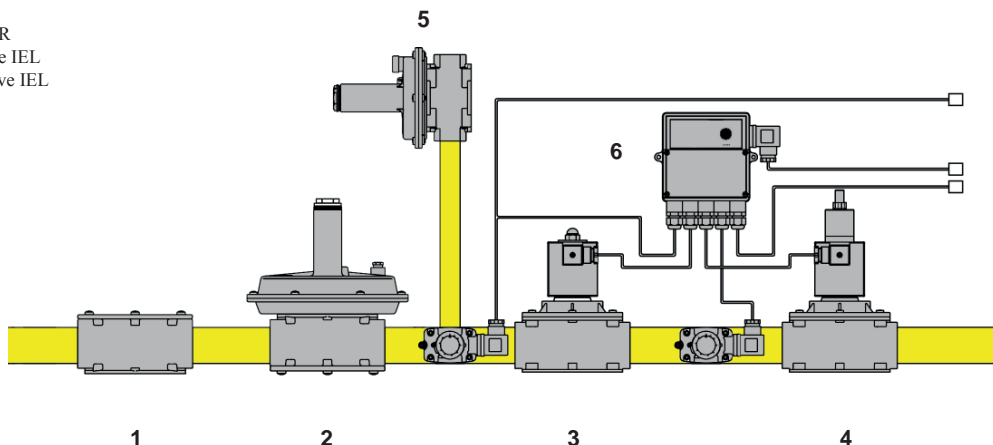

CALIBRATION

Before starting the system, pay attention that the standard regulation spring is suitable with the needed regulation pressure.

After removing the cap (1), calibrate the regulator (2) at the minimum (completely unscrewed), then start the system and checking the regulation pressure, screw the regulator (2) up to the needed pressure.

OFF SERVICE

Unscrew the cap (1) and screw the regulator (2) to its end.

MAINTENANCE

Before disassembling the device make sure that there is no pressured gas inside.

Check or substitute the diaphragms: (see fig. 1, 2 and 3)

unscrew the fixing screws (7) and remove the funnel (4), take off the safety diaphragm (6), unscrew the central nut (25) that fixes the working diaphragm (22) (between two discs) to the central pin (9).

Reassemble doing backward the same operation, paying attention when tightening the nut (25) not to turn the diaphragms (stop the disc (21) on the diaphragm (22) with the free hand).

Check the filtering organ (11) on threaded body: (see fig. 1 and 2)

unscrew the fixing screws (15) and remove the bottom cover (14).

Remove the filtering component (11), clean it with water and soap, blow it with compressed air or substitute it if is necessary. Reassemble it in its original position in its special guide (as in the picture below).

Reassemble the bottom (14) being sure that the central pin (9) is centred in the bottom hole (14).

Check the filtering organ (11) on flanged body: (see fig. 3)

unscrew the fixing screws (15) and remove the bottom cover (14).

Remove the filtering component (11), clean it with water and soap, blow it with compressed air or substitute it if is necessary.

Reassemble it in its original position being sure, when reassembling the bottom (14), that the filter (11) is positioned inside the special guides of the same bottom (14) (see fig. 3).

Assembling the bottom (14), pay attention to the teflon ring (17), it must be put inside the special guide (18).



All operations must be carried out only by qualified personnel.

VIEW: body without bottom

Filtering organ guides

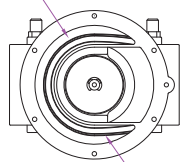

Filtering organ must be put inside these guides

Filtering organ guides

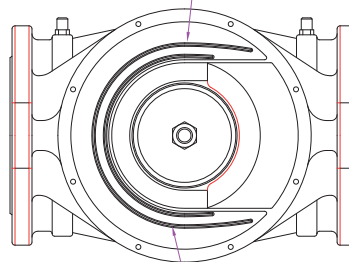

Filtering organ must be put inside these guides

THE CHOICE OF THE REGULATOR

The choice of a regulator is very important; first of all you need to know:

1. The available input pressure (P1) in the distribution net.
2. The output pressure (P2) necessary at the starting of the burner's ramp to grant the required (Q) potential (Kcal or m³/h).

Then an ideal filter regulator should be chosen considering that the flux speed mustn't exceed 30 m/s (see ideal maximum values in following table).

If you need to exceed these flows we suggest to install an overflow valve.

Connections	Q. max (Nm ³ /h)	Flux speed
DN 15	~ 19	~ 30 m/s
DN 20	~ 34	~ 30 m/s
DN 25	~ 53	~ 30 m/s
DN 32	~ 87	~ 30 m/s
DN 40	~ 136	~ 30 m/s
DN 50	~ 212	~ 30 m/s
DN 65	~ 358	~ 30 m/s
DN 80	~ 543	~ 30 m/s
DN 100	~ 848	~ 30 m/s

- From the diagram ΔP - FLOW of regulators you must choose the smallest regulator assuring the necessary flow (Q) a load loss ΔP lower than the difference between the net pressure (P1) and the necessary pressure at the starting of the burner's ramp (P2).

FOR FURTHER INFORMATION PLEASE CONTACT OUR TECHNICAL OFFICE.

