

GAS PRESSURE REGULATORS WITH RELIEF VALVE

Serie IR3/5 ... DN 15 ÷ 25



DESCRIPTION

These regulators are used both in domestic and industrial installations that use natural gas, LPG or other not corrosive gases (dry gases).

Pmax = 3 bar

Pmax = 5 bar

COMPACT versions **IRC3/IRC5** are preferable for small installations.

This devices are equipped with the following safety devices and accessories:

- **relief valve:** it vents outside small quantity of gas in case there are downstream regulator overpressure. That exhaust it is conveyed outside in case of installation in environment with bad ventilation.
- **outlet pressure test point.**

- EC certified according to EN 88-2 and EN 334
- In conformity with the 2009/142/EC Directive (Gas Directive)
- In conformity with the 2014/38/EU Directive (PED Directive)
- In conformity with the 2014/34/EU Directive (ATEX Directive)

IDENTIFICATION

IR C 3 02N 628 A B

Single stage gas pressure regulator with relief valve **series IR...**

Types
N = STANDARD version (Q max = 100 m³/h)
C = COMPACT pressure filter regulator without safety shut off (Q max = 25 m³/h)

Pmax
3 = Pmax 0,5 ÷ 3 bar
5 = Pmax 0,5 ÷ 5 bar

Connections

Threaded			
Code	GAS	Code NPT	NPT
02	DN 15 (G 1/2")	02N	DN 15 (NPT 1/2")
03	DN 20 (G 3/4")	03N	DN 20 (NPT 3/4")
04	DN 25 (G 1")	04N	DN 25 (NPT 1")

B = biogas

Versions
A = with relief valve

Settings: see next page
628 = setting spring (mbar)
 (P2+diff. relief valve range)
817 = setting spring (mbar)
 (P2+diff. relief valve range)

NOTE: not all combinations are possible
 Please contact the technical department.

SETTINGS

Version	P2 (mbar)	Differential relief valve range (mbar)	Code P. max 0,5 ÷ 3 bar P. max 0,5 ÷ 5 bar
IRC COMPACT version DN 15 - 20 - 25	10 ÷ 25	5 ÷ 12	628
	10 ÷ 25	10 ÷ 60	603
	25 ÷ 35	10 ÷ 60	604
	35 ÷ 80	10 ÷ 60	605
	80 ÷ 120	10 ÷ 60	631
	110 ÷ 200	10 ÷ 60	606
	110 ÷ 200	60 ÷ 110	632
IRN STANDARD version DN 15 - 20 - 25	10 ÷ 25	5 ÷ 10	628
	10 ÷ 25	10 ÷ 60	603
	20 ÷ 30	5 ÷ 10	629
	20 ÷ 30	10 ÷ 60	604
	30 ÷ 60	10 ÷ 60	605
	60 ÷ 90	10 ÷ 60	634
	90 ÷ 170	10 ÷ 60	606
	110 ÷ 180	60 ÷ 110	635
	170 ÷ 400*	40 ÷ 200*	607*
	300 ÷ 650*	40 ÷ 200*	046*
600 ÷ 1500*	40 ÷ 200*	058*	

Version	P2 (mbar)	OPSO range (mbar)	UPSO range (mbar)	Differential relief valve range (mbar)	Code P. max 0,5 ÷ 5 bar
IRC COMPACT version DN 15 - 20 - 25	10 ÷ 25	20 ÷ 70	7 ÷ 20	5 ÷ 12	817
	10 ÷ 25	20 ÷ 70	10 ÷ 30	10 ÷ 60	816
	25 ÷ 35	40 ÷ 90	10 ÷ 30	10 ÷ 60	819
	35 ÷ 80	50 ÷ 180	20 ÷ 50	10 ÷ 60	821
	80 ÷ 120	120 ÷ 260	20 ÷ 50	10 ÷ 60	822
	110 ÷ 200	120 ÷ 260	50 ÷ 100	10 ÷ 60	823
	110 ÷ 200	200 ÷ 550	50 ÷ 100	60 ÷ 110	824
IRN STANDARD version DN 15 - 20 - 25	10 ÷ 25	20 ÷ 70	7 ÷ 20	5 ÷ 10	817
	10 ÷ 25	40 ÷ 90	7 ÷ 20	10 ÷ 60	818
	20 ÷ 30	40 ÷ 90	10 ÷ 30	5 ÷ 10	820
	20 ÷ 30	40 ÷ 90	10 ÷ 30	10 ÷ 60	819
	30 ÷ 60	50 ÷ 180	10 ÷ 30	10 ÷ 60	834
	60 ÷ 90	120 ÷ 260	20 ÷ 50	10 ÷ 60	822
	90 ÷ 170	120 ÷ 260	50 ÷ 110	10 ÷ 60	823
	110 ÷ 180	200 ÷ 550	50 ÷ 110	60 ÷ 110	835
	170 ÷ 400*	200 ÷ 550	50 ÷ 110	40 ÷ 200*	825
	300 ÷ 650*	500 ÷ 1000*	50 ÷ 110	40 ÷ 200*	836
600 ÷ 1500*	500 ÷ 1000*	50 ÷ 110	40 ÷ 200*	837	

GENERAL DATA

TECHNICAL DATA

- Use: not aggressive gases of the 3 families (dry gases)
- Threaded connections Rp: (DN 15 - DN 20 - DN 25) according to EN 10226
- On request ANSI 150 flanged connections
- Min. working pressure: 0,5 bar
- Max. working pressure: 3 or 5 bar (see product label)
- Intervention pressure range: see springs table
- Environment temperature: -20 ÷ +60 °C
- Max superficial temperature: 60 °C
- Shut closing time: < 1 s
- Relief valve: tested according to EN 334
- Vent connection G 1/4"
- Mechanical strength: Group 2 (according to EN 13611:2007)
- Safety factor: f=4 (5*4 = 20 bar) according to EN 88-2 point 7.2
- Filtration: 50 µm
- Filtration class: G 2 (according to EN 779)

MATERIALS

- Die-cast aluminium (UNI EN 1706)
- OT-58 brass (UNI EN 12164)
- 11S aluminium (UNI 9002-5)
- Galvanized and 430 F stainless steel (UNI EN 10088)
- NBR rubber (UNI 7702)
- Nylon 30% glass fibre (UNI EN ISO 11667)
- Viledon

DIMENSIONS

**Overall dimensions in mm
COMPACT version IRC3/IRC5**

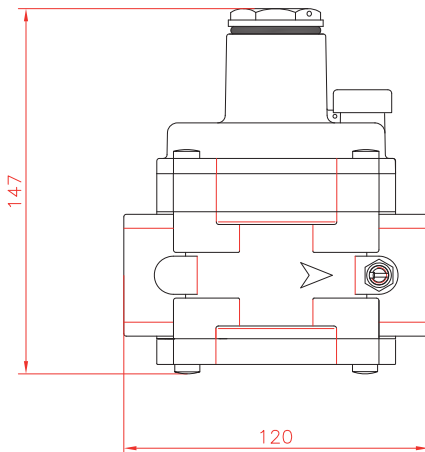

Connections	L	H	Weight (Kg)
DN 15	120	147	1,05
DN 20	120	147	1,05
DN 25	120	147	1,05

**Overall dimensions in mm
STANDARD version IRN3/IRN5**

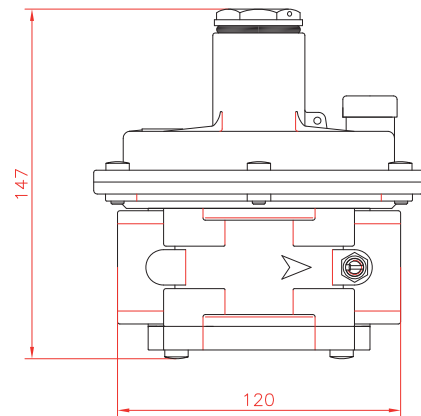

Connections	L	H	Weight (Kg)
DN 15	120	147	1,15
DN 20	120	147	1,15
DN 25	120	147	1,15

COMPONENTS

**IRC3 / IRC5
COMPACT version
Q max = 25 m³/h**

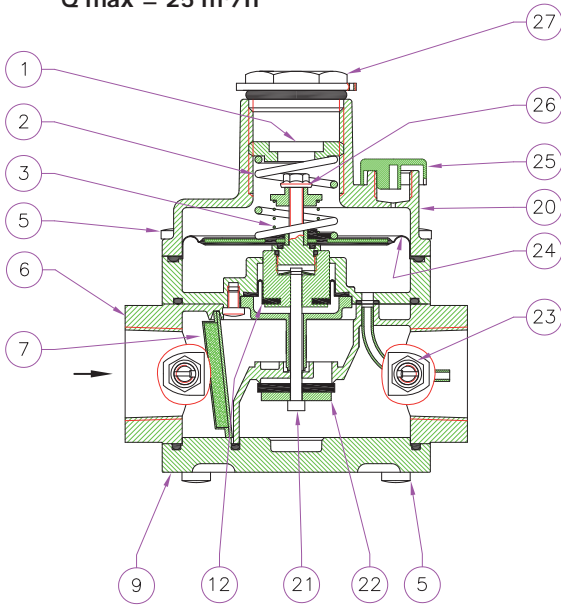

**IRN3 / IRN5
STANDARD version
Q max = 100 m³/h**

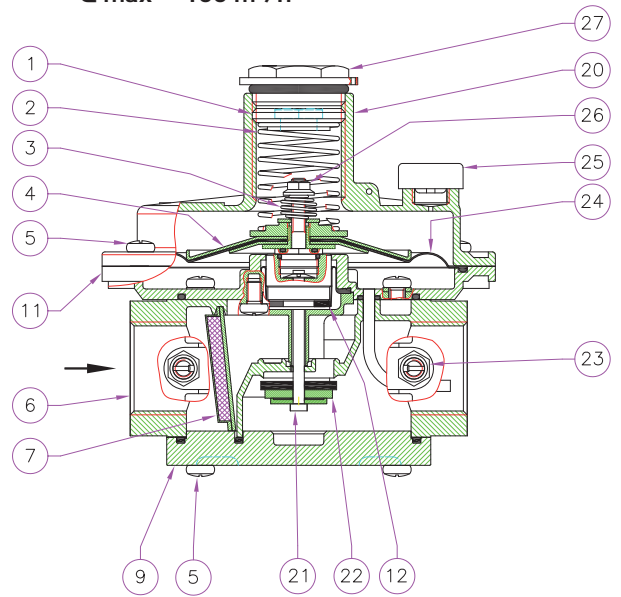

LEGEND

- | | | |
|---------------------------------|--|---------------------------------|
| 1 - P2 calibration screw | 6 - Body | 20 - Funnel |
| 2 - P2 setting spring | 7 - Filtering organ | 21 - Central pin (regulator) |
| 3 - Relief valve setting spring | 9 - Bottom | 22 - Closure member (regulator) |
| 4 - Diaphragm upper disc | 11 - Flange (only on standard version) | 23 - Pressure nipple |
| 5 - Fixing screws | 12 - Compensation diaphragm | 24 - Working diaphragm |
| | | 25 - Antidust cap |
| | | 26 - Relief calibration |
| | | 27 - Closing cap (regulator) |
| | | 28 - Special key for setting |

SETTINGS SPRINGS

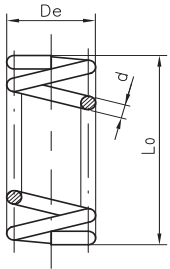

Dimension Legend

d=diameter
De = external diameter
Lo= length
it = total number of turns

	DN 15 - DN 20 - DN 25 COMPACT			DN 15 - DN 20 - DN 25 STANDARD		
	SETTING (mbar)	CODE	DIMENSIONS (d x De x Lo x it) (mm)	SETTING (mbar)	CODE	DIMENSIONS (d x De x Lo x it) (mm)
P2 (mbar) <i>* = strengthen diaphragm</i>	10 ÷ 25	018	1,5x29x46x6	10 ÷ 25	018	1,5x29x46x6
	25 ÷ 35	019	1,5X29X58X7	20 ÷ 30	019	1,5X29X58X7
	35 ÷ 80	020	2X29X49X7	30 ÷ 60	020	2X29X49X7
	80 ÷ 120	022	2X29X66X7	60 ÷ 90	022	2X29X66X7
	110 ÷ 200	024	2,5X29X50X7	90 ÷ 170	024	2,5X29X50X7
				110 ÷ 180	025	2,5X29X60X7,75
				170 ÷ 400*	047	3,5X29,8X64X9
				300 ÷ 650*	046	3,5X29,8X98X11,5
				600 ÷ 1500*	058	4X29X98X8
Differential relief valve range (mbar)	5 ÷ 12	004	0,9x17x45x7	5 ÷ 10	004	0,9x17x45x7
	10 ÷ 60	053	0,9x11x5x20,5x8	10 ÷ 60	053	0,9x11x5x20,5x8
	60 ÷ 110	008	1,1x8x15x6	60 ÷ 110	008	1,1x8x15x6
				40 ÷ 200*	056	2x17x29x6

PRESSURE DROP DIAGRAM

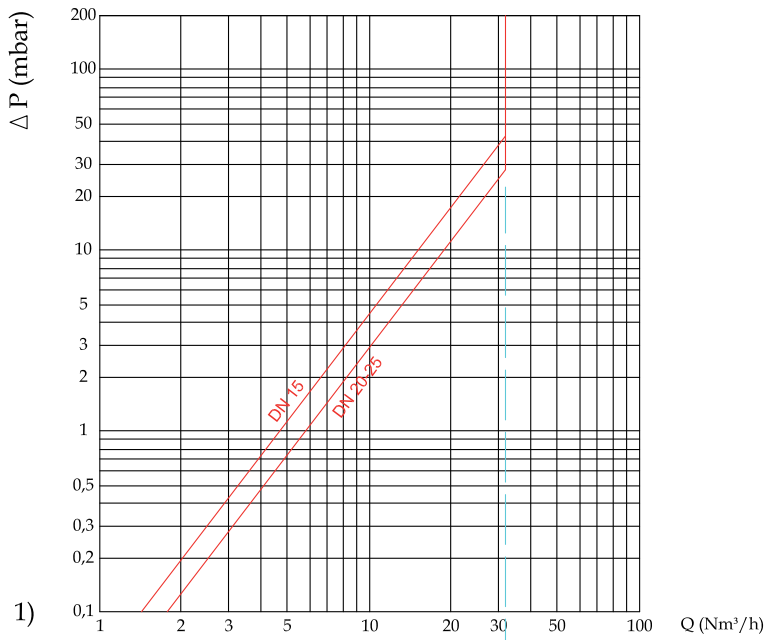

**IRC3 / IRC5
COMPACT version
Q max = 25 m³/h**

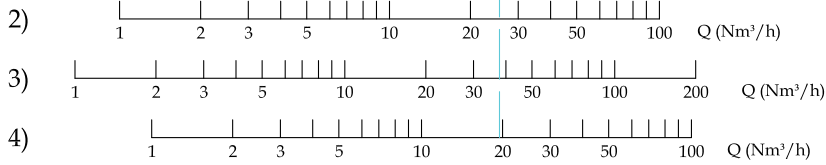

NATURAL GAS

AIR

TOWN GAS

LPG

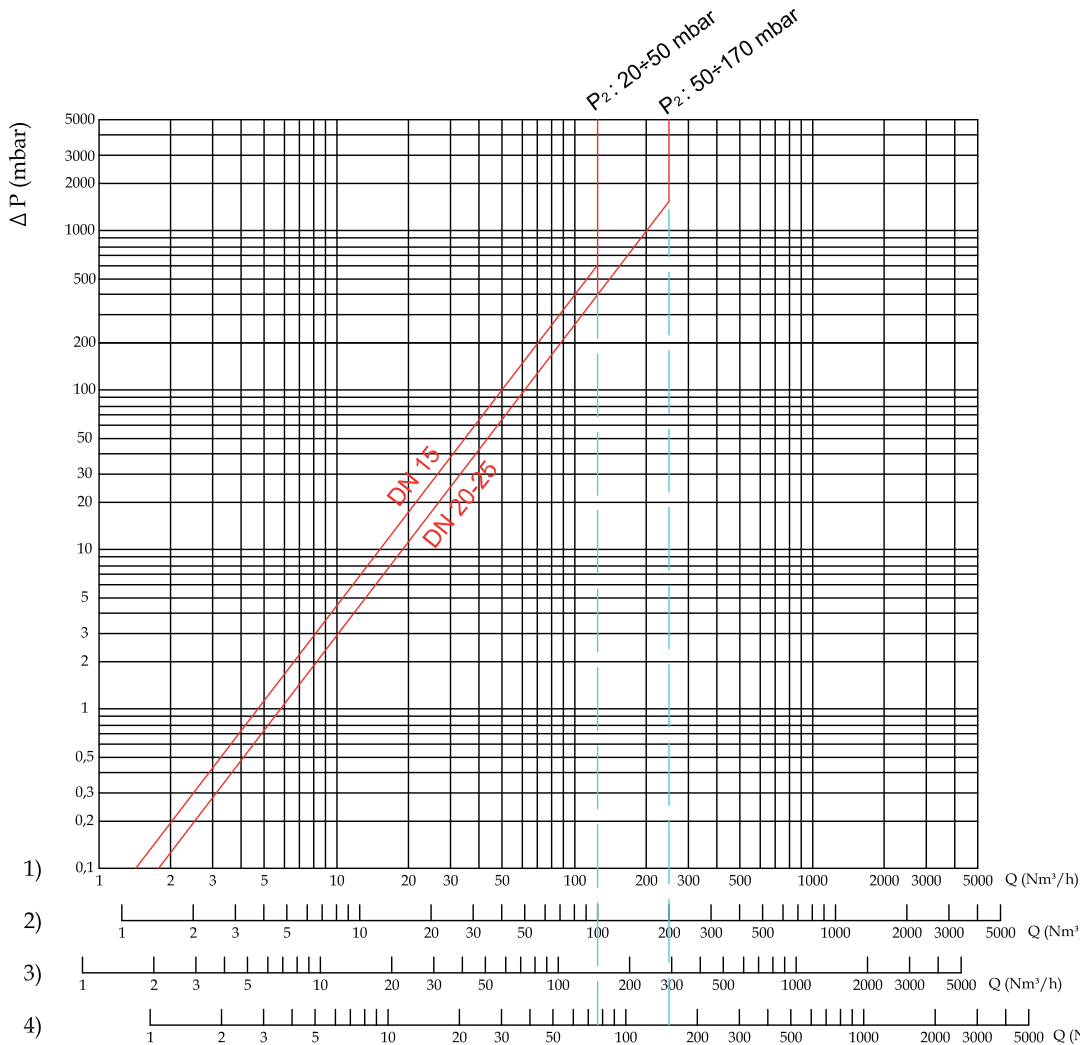

**IRN3 / IRN5
STANDARD version
Q max = 100 m³/h**

NATURAL GAS

AIR

TOWN GAS

LPG

STABILIZATION CURVES

IRC3 / IRC5 COMPACT version

P2 = 20 mbar

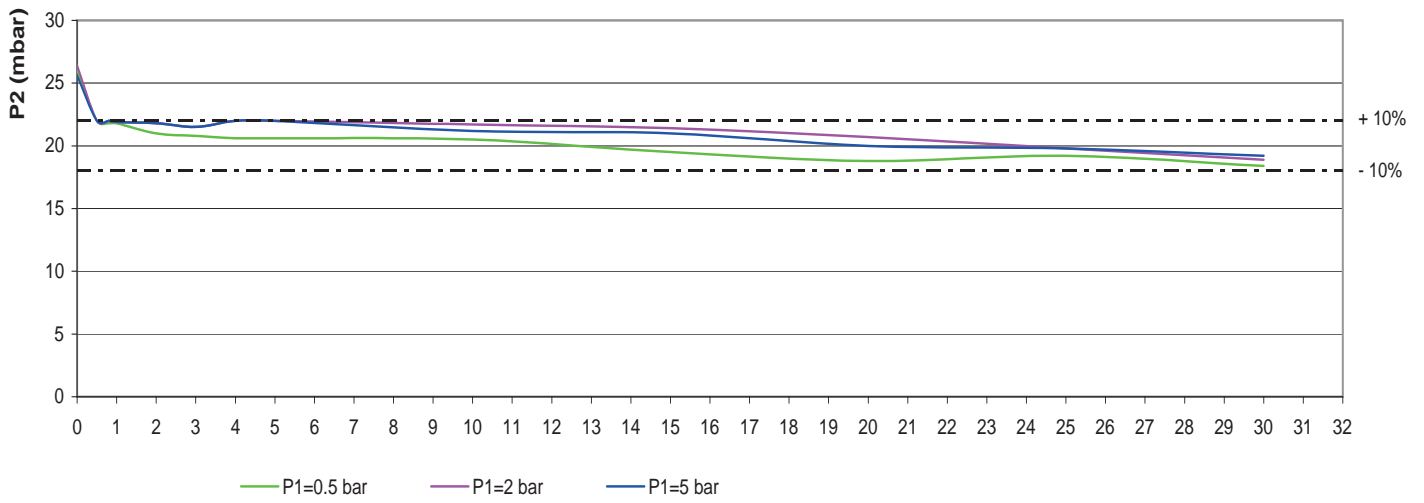

P2 = 30 mbar

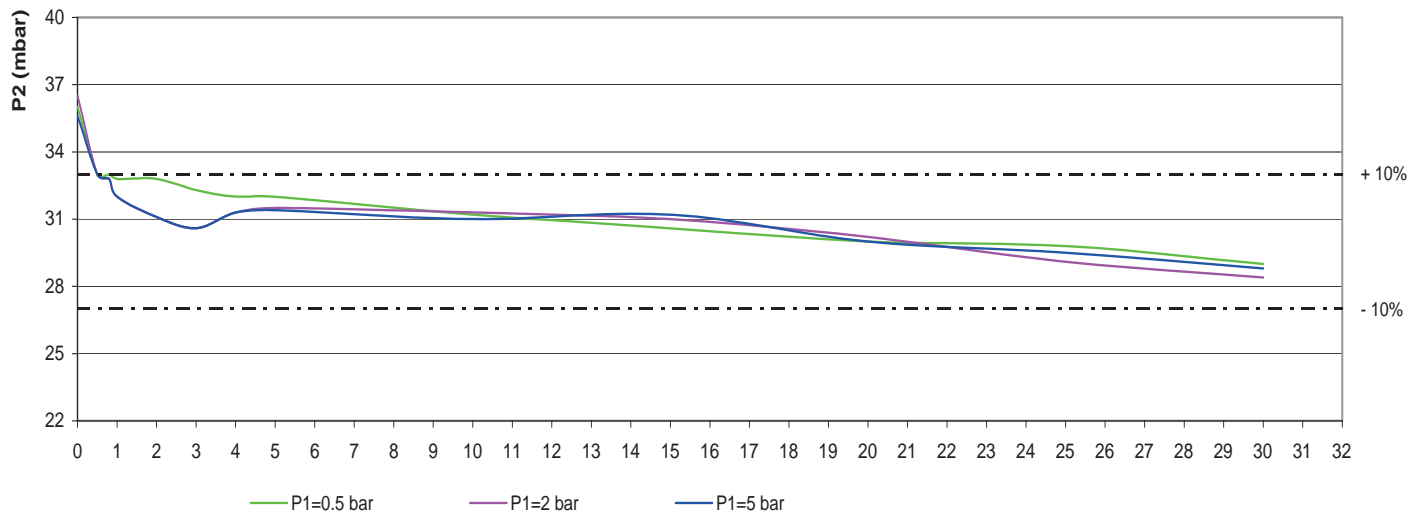

P2 = 100 mbar

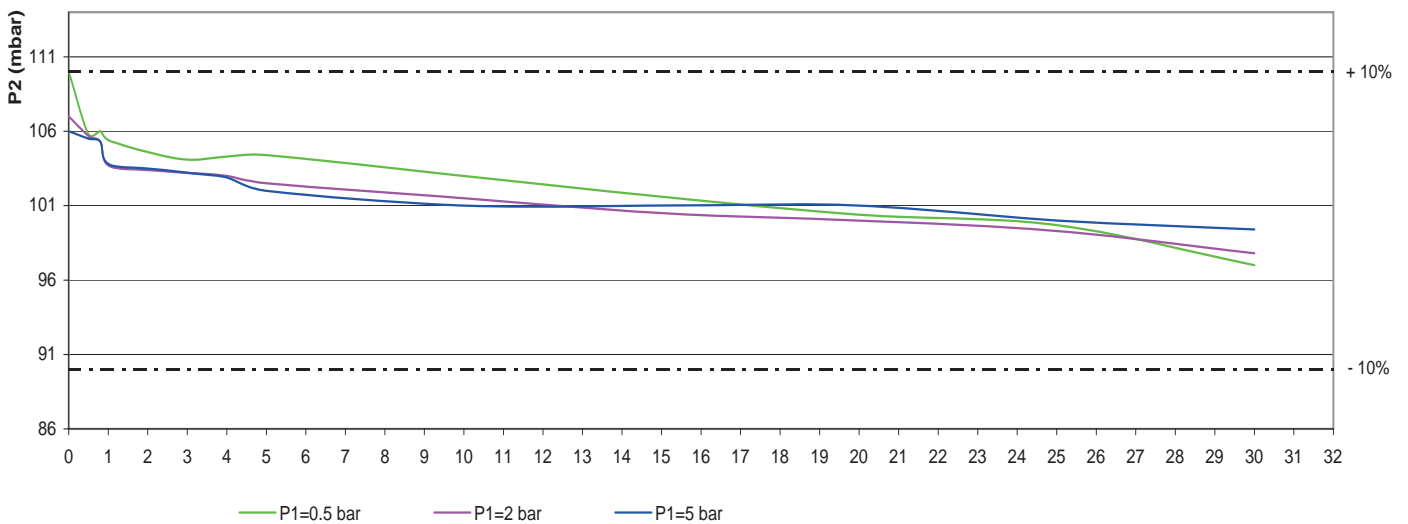

STABILIZATION CURVES

IRC3 / IRC5 STANDARD version

P2 = 20 mbar

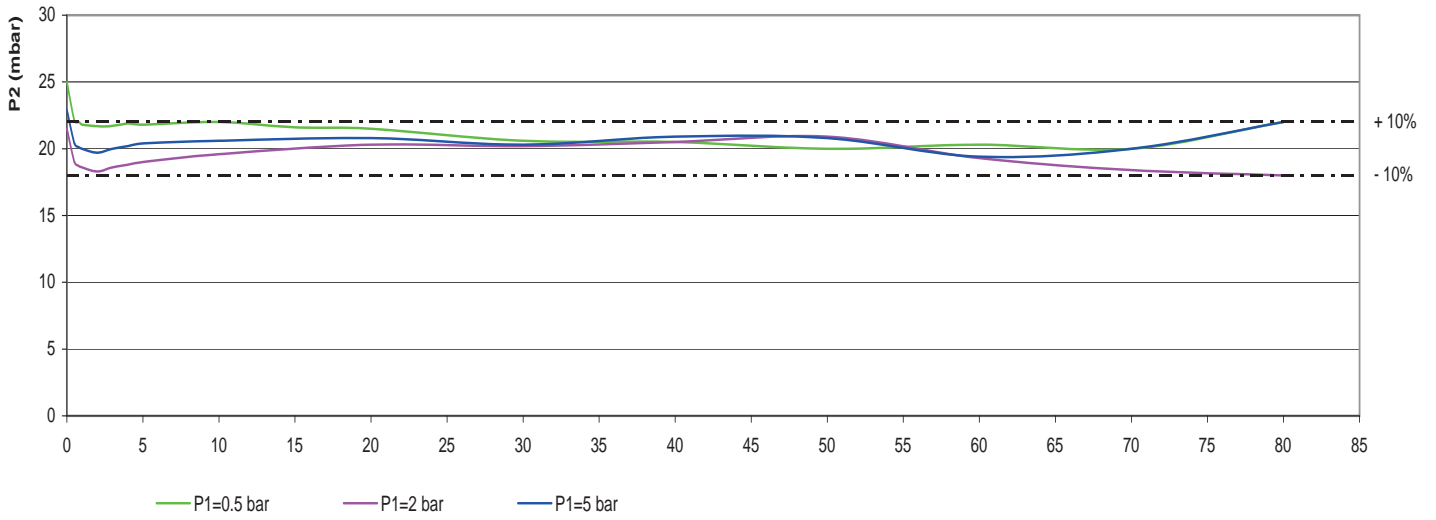

P2 = 30 mbar

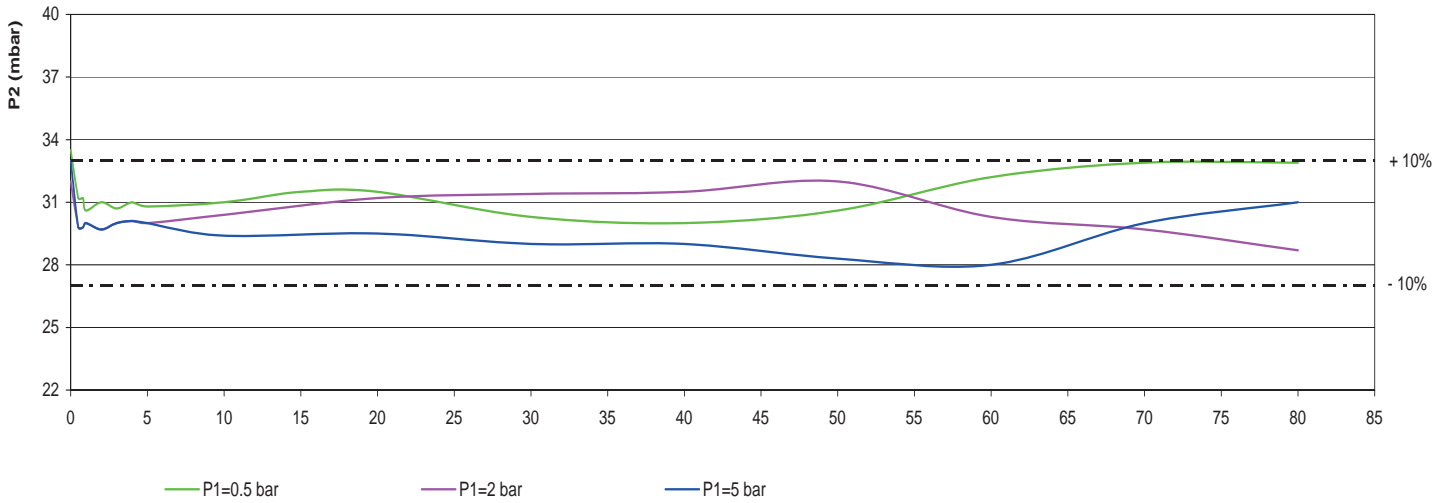

P2 = 100 mbar

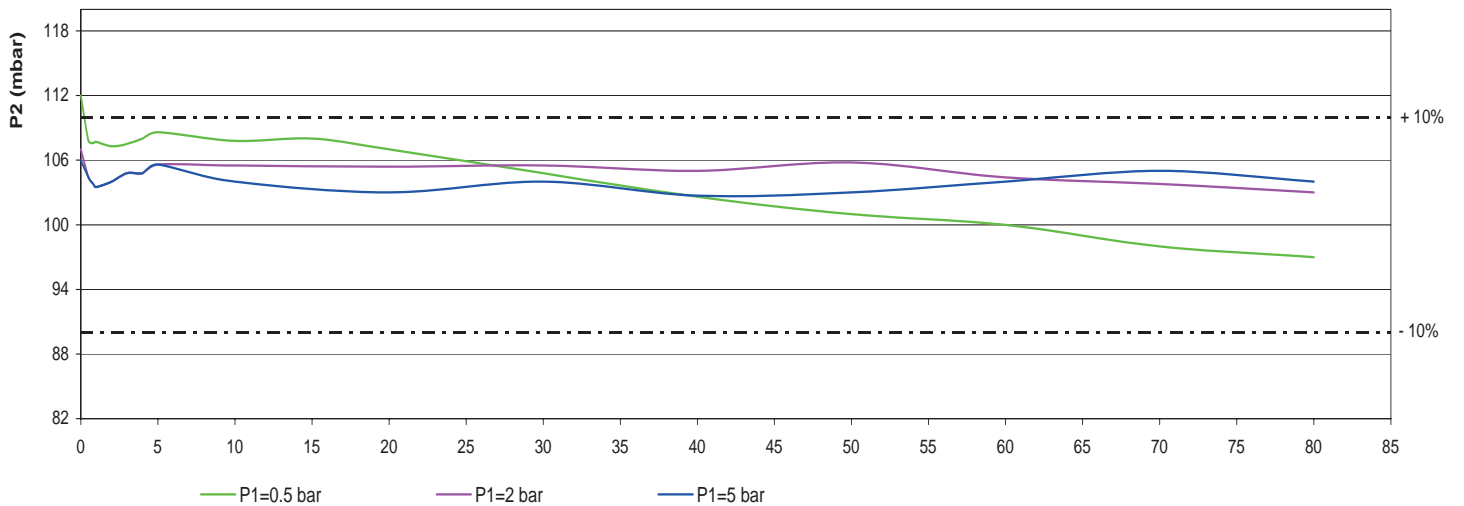

INSTALLATION

The regulator is in conformity with the Directive 2014/34/EU as device of group II, category 2G and as device of group II, category 2D; for this reason it is suitable to be installed in the zones 1 and 21 (besides in the zones 2 and 22) as classified in the attachment I to the Directive 99/92/EC.

The regulator is not suitable to be used in zones 0 and 20 as classified in the already said Directive 99/92/EC.

To determine the qualification and the extension of the dangerous zones, see the norm CEI EN 60079-10-1.

The device, if installed and serviced respecting all the conditions and the technical instructions of this document, is not source of specific dangers: in particular, there is no emission in the atmosphere of inflammable substance only occasionally.

The regulator can be dangerous as regards to the presence close to it of other devices only in case of damage either of the working diaphragm or of the safety one: only in this case the regulator is a source of emission of the continue degree explosive atmosphere and, so, it can originate dangerous areas 0 as defined in the 99/92/EC Directive.

In conditions of particularly critic installation (places not protected, lack of servicing, lacking availability of ventilation) and, especially in presence, close to the regulator, of potential sources of primer and/or dangerous devices during the normal working because susceptible to origine electric arcs or sparks, it is necessary to value before the compatibility between the regulator and these devices.

In any case it is necessary to take any useful precaution to avoid that the regulator could be origin of areas 0: for example yearly periodical inspection of regular working, possibility to change the emission degree of the source or to attend on the exhaust outside the explosive material.

For this, it is possible to connect the threaded hole G 1/4" outside by a copper pipe removing the anti-dust cap (fig. 1, 2 and 3 (24), fig. 4 (15)).



Installation must be in compliance with local law in force!

**WARNING: Read carefully the instruction sheet of each product before installing.
Installation and maintenance must be carried out by qualified personnel.**

- The gas supply must be shut off before installation.
- Check that the line pressure **DOES NOT EXCEED** the maximum pressure stated on the product label.
- The regulator is normally installed before the user. It must be installed with the arrow on the body (10) towards the user.
- It can be installed in any position but it is preferable the installation with the spring (3) in vertical position (see fig. 1, 2 and 3). Outside the regulator, downstream of it, there is a checking pressure-tap for the control of the regulation pressure.
- During installation take care not to allow debris or scraps of metal to enter the device.
- Check that the pipeline thread is not too long: overlong threads may damage the body of the device when screwed into place.
- Always check taht the installation is gas-tight after istallation.

EXAMPLE OF INSTALLATION

1. gas filter IF
2. filter regulator IFR
3. fast opening valve IEL
4. slow opening valve IEL
5. overflow valve
6. leak tester

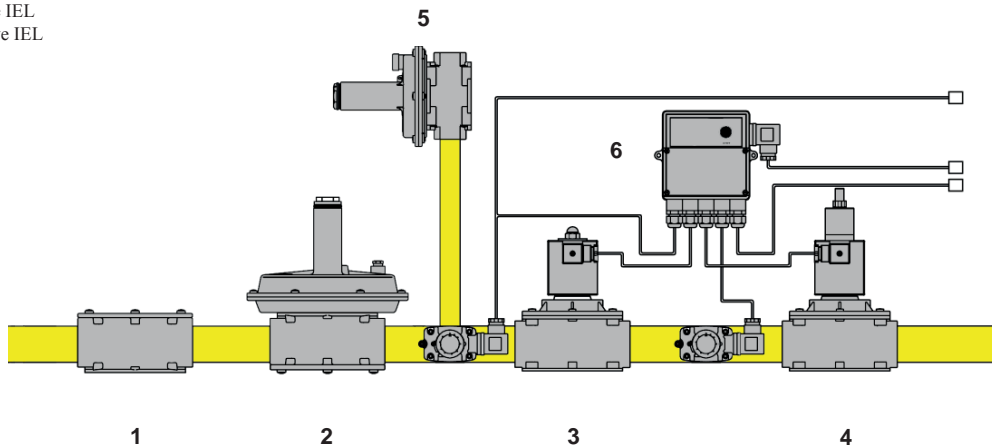

FOR FURTHER INFORMATION PLEASE CONTACT OUR TECHNICAL OFFICE.